

D2C
Designed to Customer

Reich



FLEXDUR

盘式联轴器

www.reich-kupplungen.com



SIMPLY **POWERFUL.**





D2C – Designed to Customer

“为客户量身定制”原则，是 REICH 的成功秘诀。除目录中的产品外，我们还可根据客户要求对联轴器进行开发。

结构设计大多采用模块化构件，以提供经济有效的客户解决方案。我们与合作伙伴之间特有的紧密合作形式包括咨询、开发、设计、制造、集成于既有使用环境，以及客户专享的生产和物流概念以及全球售后服务。这种以客户为导向的理念既适用于系列产品，也适用于小批量产品的开发。

客户满意、灵活、优质、交付能力和客户需求适应能力诸项要素构成了 REICH 企业哲学的根基。

REICH 交付给您的不仅仅是一台联轴器，更是一项解决方案：

Designed to Customer – SIMPLY **POWERFUL**.

D2C
Designed to Customer



FLEXDUR

目录

联轴器说明

- 04** 一般技术说明
- 05** 优势与益处
- 06** 标准型号
- 08** 特殊型号
- 10** 一般技术数据
- 16** 联轴器大小的选择

尺寸表

- 18** 型号 N + S
- 20** 型号 CA + CB
- 22** 型号 NO + SO
- 24** 型号 NX + SX
- 26** 型号 NZ + SZ
- 28** 型号 F
- 30** 型号 NY + SY
- 32** 型号 NK + SK
- 34** 型号 SP-CA + SP-CB

FLEXDUR

一般技术说明

FLEXDUR

扭转刚性、柔性联轴器

作为传动元件，不锈钢制成的柔性膜片组在带衬套的型式中使用。由于精确配套的衬套具有特殊造型，因此在组装状态下对膜片组的应力均匀分布。通过高强度的配合螺栓，可以实现无扭转间隙扭矩传递。

FLEXDUR (缩写：FD-C) 采用模块化构造方式，因此可适应各种安装情况：

作为带一个柔性膜片组的单联杆联轴器，FLEXDUR 1 (例如 N 型) 可以补偿轴向偏差和角偏差。

作为带两个柔性膜片组的双联杆联轴器，FLEXDUR 2 (例如 S 型) 可补偿轴向偏差、径向偏差和角偏差，从而在各侧面都可伸缩。标准配置下，可提供不同的安装长度。

除了标准的 FD-C 版，还有一个加强的膜片版 FD-CL。以及特殊版本，例如可根据要求提供垂直安装位置。

要实现完全无间隙的连接，可以使用带夹紧装置的型号。

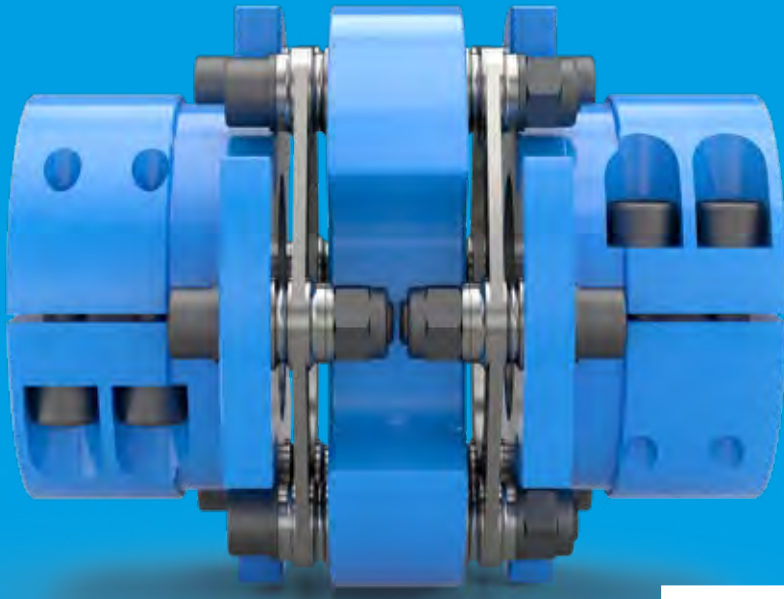

FLEXDUR

额定扭矩从 18 Nm 至 130 000 Nm

FLEXDUR 优势与益处

FLEXDUR 联轴器的最重要特性和相关优势：

→ 扭转刚性和无扭转间隙扭矩传递	→ 即使在过零点的交变载荷下依然具有长使用寿命
→ 轴向、径向和角度轴偏差补偿	→ 设备通过减少负载实现高运行稳定性，由此提升生产率
→ 由于采用柔性膜片组，轴偏差的复位力低	→ 使用寿命长，寿命周期成本更低
→ 无需维护或润滑	→ 减少使用期间的工作量。缩短停机时间。凭借减少维护优化运行成本
→ 适合在 -25 °C 至 $+250\text{ °C}$ 的环境温度下使用	→ 可在非常恶劣的条件下整体使用
→ 紧凑的构造方式，也适用于高转速	→ 应用范围广，此外还适用于安装空间小的应用
→ 轴充分对齐后，使用寿命几乎无限且几乎无磨损	→ 经济性高
→ 由于 ATEX，应用范围得以扩大 	→ 高度安全，因为它可以在易爆环境中使用
→ 模块化构造方式	→ 性价比高。 投资成本低，经济性高

FLEXDUR

标准型号

单联杆 FD-C 1



FD-C N
标准



双联杆 FD-C 2



FD-C CA
结构短小紧凑



双联杆 FD-C 2



FD-C S DBSEmin
标准，结构短小



双联杆 FD-C 2



FD-C CB
紧凑



双联杆 FD-C 2



FD-C S
标准



FD-C NO

法兰版



单联杆 FD-C 1

FD-C SO DBSEmin

法兰版，结构短小



双联杆 FD-C 2

FD-C SO

法兰版



双联杆 FD-C 2

FLEXDUR

特殊型号

单联杆 FD-C 1



FD-C NX
带内部锁紧装置

单联杆 FD-C 1



FD-C NZ
带外夹紧件



双联杆 FD-C 2



FD-C SX DBSEmin
带内部锁紧装置，
结构短小

双联杆 FD-C 2



FD-C SZ DBSEmin
带外夹紧件，结构短小



双联杆 FD-C 2



FD-C SX
带内部锁紧装置

双联杆 FD-C 2



FD-C SZ
带外夹紧件



双联杆 FD-C 2



FD-C F
API 610+API 671



FD-C NY

带夹紧轂，分两部分



单联杆 FD-C 1

FD-C NK

带夹紧轂，开槽



单联杆 FD-C 1

FD-C SY DBSEmin

带夹紧轂，分两部分，
结构短小



双联杆 FD-C 2

FD-C SK DBSEmin

带夹紧轂，开槽，
结构短小



双联杆 FD-C 2

FD-C SY

带夹紧轂，分两部分



双联杆 FD-C 2

FD-C SK

带夹紧轂，开槽



双联杆 FD-C 2

FD-C SP-CA

结构短小紧凑
分离式过渡件



双联杆 FD-C 2

FD-C SP-CB

紧凑，分离式过渡件



双联杆 FD-C 2

FLEXDUR FD-C

一般技术数据



标准型号

联轴器大小	FD-C 1 单联杆联轴器								FD-C 2 双联杆联轴器						
	额定扭矩	最大扭矩	最大转速	允许的偏差			惯性力矩	扭簧刚度	过渡件	允许的偏差			惯性力矩	扭簧刚度	
	T_{KN} [Nm]	T_{Kmax} [Nm]	n^2 [min ⁻¹]	ΔK_a [± mm]	ΔK_r [mm]	ΔK_w [°]	J [kgm ²]	C_T [kNm/转]	DBSE ¹⁾ [mm]	ΔK_a [± mm]	ΔK_r [mm]	ΔK_w [°]	J [kgm ²]	C_T [kNm/转]	
FD-C 40	18	31.5	16700	0.4	0	1.0	0.00002	19	16.0	0.8	0.2	2	0.00004	9	
									26.0						0.3
FD-C 53	90	157	16200	0.4	0	1.0	0.00011	90	30.0	0.8	0.3	2	0.00016	44	
									43.0						0.4
FD-C 72	170	295	12200	0.5	0	1.0	0.00049	173	31.2	1.1	0.3	2	0.00071	84	
									60.0						0.8
									100.0						1.5
									140.0						2.2
FD-C 89	320	560	9900	0.6	0	1.0	0.0016	281	37.6	1.2	0.4	2	0.0022	136	
									70.0						1
									80.0						1.1
									100.0						1.5
									140.0						2.1
FD-C 118	750	1310	7500	0.8	0	1.0	0.0059	637	46.3	1.6	0.5	2	0.0080	309	
									100.0						1.4
									140.0						2.1
									180.0						2.8
FD-C 142	1350	2360	6200	1.0	0	1.0	0.014	1173	55.0	2.1	0.7	2	0.018	569	
									100.0						1.5
									140.0						2.1
									180.0						2.8
FD-C 168	2400	4200	5250	1.2	0	1.0	0.035	2000	62.6	2.5	0.9	2	0.039	952	
									100.0						1.4
									140.0						2.1
									180.0						2.8
FD-C 200	4000	7000	4400	1.4	0	1.0	0.084	2992	140.0	2.8	2	2	0.12	1306	
									180.0						2.7
FD-C 238	6500	11375	3650	1.7	0	1.0	0.23	5269	140.0	3.4	2	2	0.34	2467	
									180.0						2.6
									250.0						3.8
FD-C 295	21000	36750	2950	1.1	0	0.5	0.70	21848	200.0	2.2	1.4	1	1.07	8995	
									250.0						1.8
FD-C 345	36000	63000	2500	1.3	0	0.5	1.75	37204	224.0	2.6	1.6	1	2.62	14975	
									250.0						1.8
									300.0						2.2
FD-C 420	74000	129500	2050	1.6	0	0.5	3.26	46192	280.0	3.2	2.5	1	5.35	18116	
FD-C 510	130000	227500	1700	2.0	0	0.5	8.65	87706	350.0	4	3	1	14.43	36134	

1) 根据要求, DBSE 最高可达 3000 mm 2) 如需更高的转速, 请联系我们

FLEXDUR FD-CL

一般技术数据

标准型号

联轴器大小	FD-CL 1 单联杆联轴器								FD-CL 2 双联杆联轴器						
	额定扭矩	最大扭矩	最大转速	允许的偏差			惯性力矩	扭簧刚度	过渡件	允许的偏差			惯性力矩	扭簧刚度	
	T_{KN} [Nm]	$T_{K max}$ [Nm]	$n^{2)}$ [min ⁻¹]	ΔK_a [± mm]	ΔK_r [mm]	ΔK_w [°]	J [kgm ²]	C_T [kNm/转]		DBSE ¹⁾ [mm]	ΔK_a [± mm]	ΔK_r [mm]	ΔK_w [°]	J [kgm ²]	C_T [kNm/转]
FD-CL 72	230	402.5	12200	0.4	0	0.7	0.00049	184	31.4	0.8	0.2	1.4	0.00070	89	
									60.2						0.6
									100.2						1.1
									140.2						1.5
FD-CL 89	420	735.0	9900	0.5	0	0.7	0.016	312	38.0	1.0	0.3	1.4	0.00219	151	
									70.4						0.7
									80.4						0.8
									100.4						1.1
									140.4						1.6
FD-CL 118	1050	1837.5	7500	0.6	0	0.7	0.0059	743	47.1	1.2	0.4	1.4	0.00812	360	
									100.8						1.1
									140.8						1.5
									180.8						2.1
FD-CL 142	1750	3062.5	6200	0.7	0	0.7	0.014	1251	55.4	1.4	0.5	1.4	0.01840	607	
									100.4						1.0
									140.4						1.5
									180.4						2.0
FD-CL 168	3000	5250.0	5250	0.8	0	0.7	0.035	2082	62.6	1.6	0.6	1.4	0.039	990	
									100.0						1.0
									140.0						1.5
									180.0						2.0
FD-CL 200	5200	9100.0	4400	1.0	0	0.7	0.084	3142	140.4	2.0	1.5	1.4	0.12	1362	
									180.4						2.0
FD-CL 238	11000	19250.0	3650	1.2	0	0.7	0.23	6586	142.4	2.4	1.4	1.4	0.34	3035	
									182.4						1.9
									252.4						2.7
FD-CL 295	26000	45500.0	2950	0.8	0	0.4	0.70	22285	200.4	1.6	1.2	0.8	1.07	9142	
									250.4						1.5
FD-CL 345	44000	77000.0	2500	0.9	0	0.4	1.75	37868	224.4	1.8	1.3	0.8	2.62	15190	
									250.4						1.5
									300.4						1.8

1) 根据要求，DBSE 最高可达 3000 mm 2) 如需更高的转速，请联系我们

FLEXDUR FD-C

一般技术数据



特殊型号 FD-C F

FD-C 2
双联杆联轴器

联轴器大小	额定扭矩	最大扭矩	最大转速	过渡件		允许的偏差				惯性力矩		扭簧刚度	
	T_{KN}	T_{Kmax}	n	DBSE _{min}	DBSE	ΔK_a	ΔK_r 针对 DBSE _{min}	ΔK_r	ΔK_w	J 针对 DBSE _{min}	J	C_T 针对 DBSE _{min}	C_T
	[Nm]	[Nm]	[min ⁻¹]	[mm]	[mm]	[± mm]	[mm]	[mm]	[°]	[kgm ²]	[kgm ²]	[kNm/转]	[kNm/转]
FD-C 89	320	560	15800	50.0	62.0	1.2	0.7	0.93	2	0.0054	0.0055	134.0	129.6
					102.0			1.63			0.0057		116.8
FD-C 118	750	1310	12300	61.0	96.0	1.6	0.9	1.49	2	0.0184	0.0188	300.2	273.1
					136.0			2.19			0.0192		247.5
FD-C 142	1350	2360	10000	63.0	91.0	2.1	0.9	1.38	2	0.0485	0.0491	561.2	524.0
					131.0			2.08			0.0501		478.7
FD-C 168	2400	4200	8400	74.0	119.0	2.5	1.0	1.85	2	0.1114	0.1127	909.4	818.7
					189.0			3.07			0.1149		691.5
FD-C 200	4000	7000	7400	90.0	110.0	2.8	1.3	1.66	2	0.2649	0.2661	1383.4	1321.3
					180.0			2.88			0.2701		1141.8
FD-C 238	6500	11375	6000	105.4	167.4	3.4	1.5	2.56	2	0.6501	0.6618	2525.1	2335.9
					217.4			3.43			0.6713		2202.8
FD-C 295	21000	36750	4900	138.0	153.0	2.2	0.9	1.09	1	1.7477	1.7522	9573.5	9149.4
					203.0			1.53			1.7674		7972.0
FD-C 345	36000	63000	4200	155.0	177.0	2.6	1.0	1.26	1	3.9224	3.9400	17098.0	16344.8
					227.0			1.70			3.9800		14857.4

FLEXDUR FD-CL

一般技术数据

特殊型号 FD-CL F

FD-CL 2 双联杆联轴器

联轴器大小	额定扭矩	最大扭矩	最大转速	过渡件		允许的偏差				惯性力矩		扭转刚度	
	T_{KN}	$T_{K\max}$	n	$DBSE_{\min}$	DBSE	ΔK_a	ΔK_r 针对 $DBSE_{\min}$	ΔK_r	ΔK_w	J 针对 $DBSE_{\min}$	J	C_T 针对 $DBSE_{\min}$	C_T
	[Nm]	[Nm]	[min ⁻¹]	[mm]	[mm]	[± mm]	[mm]	[mm]	[°]	[kgm ²]	[kgm ²]	[kNm/转]	[kNm/转]
FD-CL 89	420	735.0	15800	50.4	62.4	1.0	0.5	0.65	1.4	0.0054	0.0055	148.0	142.7
					102.4			1.14			0.0057		127.3
FD-CL 118	1050	1837.5	12300	61.8	96.8	1.2	0.6	1.05	1.4	0.0184	0.0188	346.9	311.1
					136.8			1.54			0.0192		278.3
FD-CL 142	1750	3062.5	10000	63.4	91.4	1.4	0.6	0.97	1.4	0.0485	0.0491	596.8	554.9
					131.4			1.46			0.0501		504.4
FD-CL 168	3000	5250.0	8400	74.0	119.0	1.6	0.7	1.29	1.4	0.1114	0.1123	963.7	846.0
					189.0			2.15			0.1149		710.8
FD-CL 200	5200	9100.0	7400	90.4	110.4	2.0	0.9	1.16	1.4	0.2649	0.2661	1447.3	1379.4
					180.4			2.02			0.2701		1184.9
FD-CL 238	11000	19250.0	6000	107.8	169.8	2.4	1.0	1.81	1.4	0.6501	0.6618	3123.8	2839.3
					219.4			2.42			0.6713		2645.0
FD-CL 295	26000	45500.0	4900	138.4	153.4	1.6	0.8	0.87	0.8	1.7477	1.7522	9740.9	9302.1
					203.4			1.22			1.7674		8087.8
FD-CL 345	44000	77000.0	4200	155.4	177.4	1.8	0.9	1.01	0.8	3.9224	3.9400	17378.1	16600.6
					227.4			1.36			3.9800		15068.4

FLEXDUR FD-C

一般技术数据



特殊型号 FD-C SP

FD-C 2 双联杆联轴器

联轴器大小	额定扭矩	最大扭矩	最大转速	过渡件	允许的偏差			惯性力矩		扭簧刚度
	T_{KN}	$T_{K\ max}$	n	DBSE	ΔK_a	ΔK_r	ΔK_w	J CA	J CB	C_T
	[Nm]	[Nm]	[min ⁻¹]	[mm]	[± mm]	[mm]	[°]	[kgm ²]	[kgm ²]	[kNm/转]
FD-C 89	320	560	9900	80.0	1.2	1.2	2	0.0023	0.0024	127.1
FD-C 118	750	1310	7500	79.0	1.6	1.2	2	0.0196	0.0208	298.6
FD-C 142	1350	2360	6200	93.0	2.1	1.5	2	0.1053	0.1110	546.3
FD-C 168	2400	4200	5250	112.0	2.5	1.7	2	0.8306	0.9173	942.7
FD-C 200	4000	7000	4400	124.0	2.8	1.9	2	0.2649	0.2649	1404.8
FD-C 238	6500	11375	3650	144.0	3.4	2.2	2	0.6501	0.6501	2527.4
FD-C 295	21000	36750	2950	199.0	2.2	1.5	1	1.7477	1.7477	9843.9
FD-C 345	36000	63000	2500	223.0	2.6	1.7	1	3.9224	3.9224	16947.3

FLEXDUR FD-CL

一般技术数据

特殊型号 FD-CL SP

FD-CL 2 双联杆联轴器

联轴器大小	额定扭矩	最大扭矩	最大转速	过渡件	允许的偏差			惯性力矩		扭簧刚度
	T_{KN}	$T_{K\ max}$	n	DBSE	ΔK_a	ΔK_r	ΔK_w	J CA	J CB	C_T
	[Nm]	[Nm]	[min ⁻¹]	[mm]	[± mm]	[mm]	[°]	[kgm ²]	[kgm ²]	[kNm/转]
FD-CL 89	420	735.0	9900	80.4	1.0	0.9	1.4	0.0023	0.0024	139.6
FD-CL 118	1050	1837.5	7500	79.8	1.2	0.9	1.4	0.0076	0.0081	344.8
FD-CL 142	1750	3062.5	6200	93.4	1.4	1.0	1.4	0.0196	0.0208	580.0
FD-CL 168	3000	5250.0	5250	112.0	1.6	1.2	1.4	0.0473	0.0502	979.1
FD-CL 200	5200	9100.0	4400	124.4	2.0	1.3	1.4	0.1053	0.1110	1470.8
FD-CL 238	11000	19250.0	3650	146.4	2.4	1.6	1.4	0.2596	0.2936	3127.3
FD-CL 295	26000	45500.0	2950	199.4	1.6	1.2	0.8	0.8306	0.9173	10021.0
FD-CL 345	44000	77000.0	2500	223.4	1.8	1.3	0.8	1.8281	2.1153	17222.4

FLEXDUR

联轴器大小的选择

首先，确定服务系数 (S_f)，其由偏差系数 (S_1)、运行系数 (S_2) 和温度因素 (S_3) 生成：

$$S_f = S_1 \cdot S_2 \cdot S_3 \text{ (参见后续章节)}。$$

服务系数 (S_f) 和可传递扭矩 T 的乘积不得大于额定扭矩 T_{KN} (根据表格“一般技术数据”)。

$$T_{KN} > T \cdot S_f$$

偏差系数 S_1

表格“一般技术数据”中给出的允许偏差是不会同时出现的最大值。根据图 1，现有的轴向偏差 ΔK_a 减小了径向偏差 ΔK_r 和角偏差 ΔK_w 的允许值。总角偏差 $\Sigma \Delta K [^\circ]$ 由下式给出：

$$\Sigma \Delta K [^\circ] = \frac{\Delta K_w}{2} + \text{反正切函数} \frac{\Delta K_r}{(DBSE - S)}$$

(根据表“标准型号”第 10 页的 DBSE 和 S 值)

根据图 2，偏差系数 (S_1) 是 $\Sigma \Delta K [^\circ]$ 的函数。

运行系数 S_2

用于电动或液压发动机和燃气或蒸汽涡轮机。

工作机械

工作机械	S_2
造纸机械和纺织机械	2.00
木材加工机械；齿轮泵；输送带	1.50
机床：主驱动装置	1.75
机床：辅助驱动装置	1.10
电梯和起重机	2.00
碾磨机；冲程活塞泵	2.50
离心泵：低惯性矩，低粘度材料	1.10
离心泵：高惯性矩，高粘度材料	1.75
压床	3.00
低惯性矩通风机	1.10
高惯性矩通风机	2.00

服务系数必须增加：

- S_2+1 ：适用于配备 4 缸或 5 缸内燃机的设备
- $S_2+0.5$ ：适用于配备 6 缸内燃机、液压涡轮机或启动扭矩 ≥ 2 的设备。
- 具有高重复负载峰值的设备：
 - 增长的运行负载： $T_{KN} >$ 最大负载峰值
 - 交替的运行负载： $T_{KN} > 1.5 \times$ 最大负载峰值

温度因素 S_3

FLEXDUR 标准情况下最高使用温度可达 80 °C。如果使用带塑料环的自锁螺母，应在订购时说明更高的温度。在高于 160 °C 的温度下，根据图 3 选择系数 S_3 。

一般技术提示

此处说明的技术数据仅适用于联轴器本体以及相应的联轴器元件。使用者有责任确保没有任何构件出现使用不当。需特别注意按照待传递的扭矩检查现有连接，例如螺栓连接。必要时还需采取进一步的措施，例如使用销钉进行额外加固。同样地，使用者有责任确保轴连接和键槽连接及/或诸如张紧连接和夹紧连接等其

他种类的连接具有足够的尺寸。所有可能生锈的构件默认采用防腐处理。REICH 提供了极为广泛的联轴器产品系列，能够为几乎每一种驱动装置选取适用的联轴器产品和联轴器系统。此外还可开发客户定制解决方案，并且作为小批量或样机生产。除此之外，多种多样的计算程序能够执行所有必要的设计。

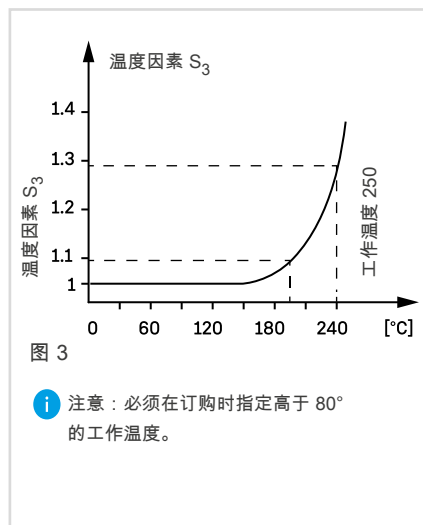
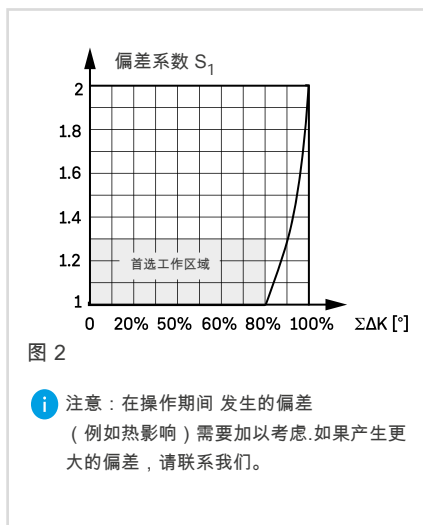
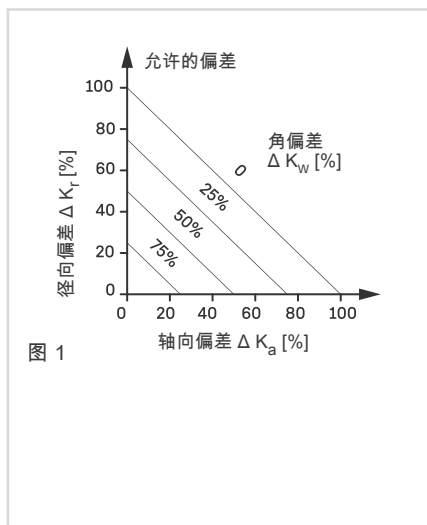

i 注意：在操作期间发生的偏差（例如热影响）需要加以考虑。如果产生更大的偏差，请联系我们。

i 注意：必须在订购时指定高于 80° 的工作温度。

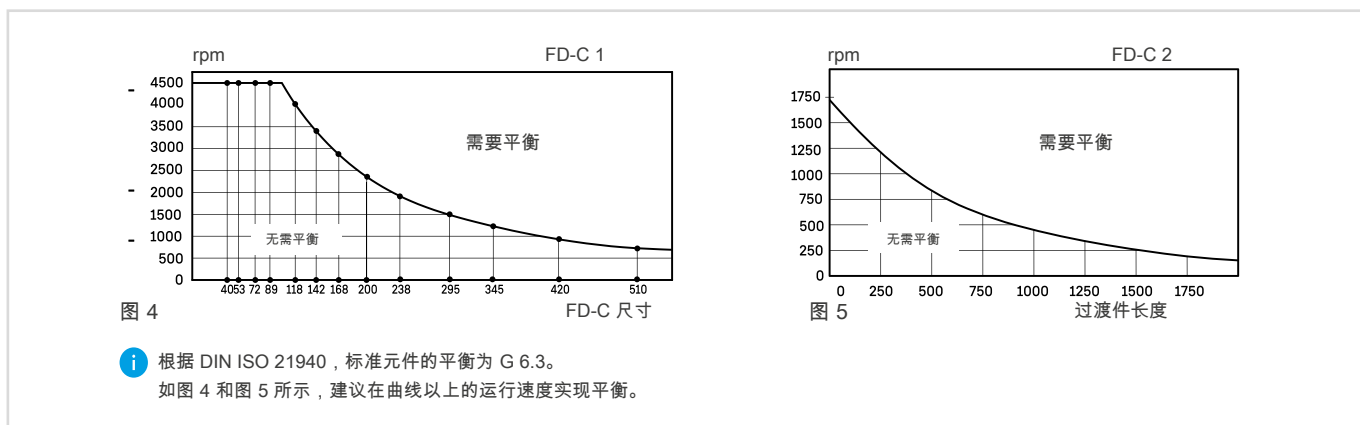

i 根据 DIN ISO 21940，标准元件的平衡为 G 6.3。如图 4 和图 5 所示，建议在曲线以上的运行速度实现平衡。

订购举例

元件型式	尺寸	螺栓数目	型式	安装情况	轮毂型式	孔型式
FD-C = 标准 FD-CL = 加强			N = 单联杆联轴器标准 S = 双联杆联轴器标准 CA = 紧凑，两个轮毂向内安装 CB = 紧凑，一个轮毂向内安装 F = 双联杆联轴器 API 610、API 671 和 ATEX 合规 SP-CA = 分离式过渡件，两个轮毂向内安装 SP-CB = 分离式过渡件，一个轮毂向内安装	轴端之间的距离 (DBSE) (在 N 型上 - 无说明)	带键槽连接的型式 - 无说明 O = 用于脱离版的法兰联轴器 K = 夹紧鞍，开槽 Z = 外夹紧件 Y = 夹紧鞍，分两部分 X = 内部锁紧装置 V ₁ = 小圆锥套型式 V ₂ = 大圆锥套型式	依照 DIN 6885/1 => Ø D ₁ 或 Ø D ₉ ，如果存在键槽连接 对于 K => Ø D ₁₁ 对于 Z => Ø D ₇ + Ø D ₆ 对于 Y => 夹紧装置类型 + Ø D ₆ 对于 X => 夹紧装置类型 + Ø D ₃
FD-C	142 -	6	S	180	X	2820.50 / 2820.55

名称：FD-C 142 - 6 S 180 X 2820.50 - X 2820.55

FLEXDUR

型号 N + S

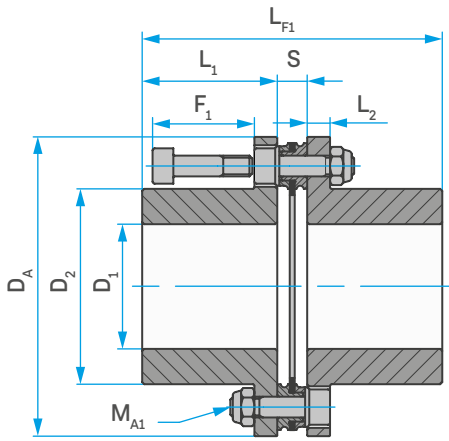

FD-C N : 标准

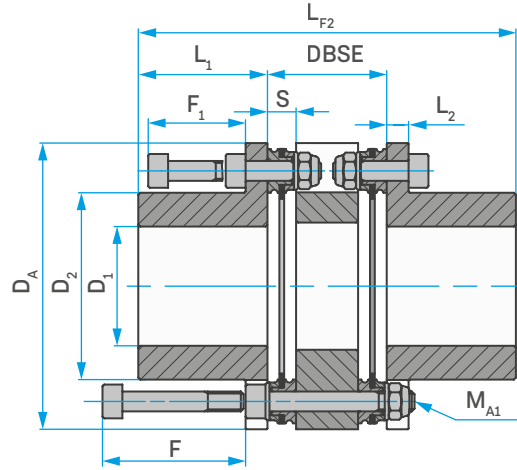

FD-C S DBSE_{min} : 标准, 结构短小



联轴器数据

联轴器大小	L ₁ [mm]	D _A [mm]	D _{1min} 预钻孔 [mm]	D _{1max} [mm]	D ₂ [mm]	F [mm]	F ₁ [mm]	L ₂ [mm]
40	17.0	40.0	6	18	26.0	25	15	4
53	24.5	53.0	6	22	32.5	43	24	5
72	39.5	70.5	10	32	47.0	43	24	5
89	45.0	88.0	14	42	62.5	53	32	8
118	55.0	116.5	15	55	82.0	67	40	10
142	60.0	140.5	19	65	98.0	82	47	11
168	75.0	166.5	25	80	118.0	94	55	12
200	90.0	198.5	30	95	141.0	-	64	14
238	125.0	238.0	39	115	169.0	-	81	16
295	160.0	295.0	59	140	205.0	-	112	22
345	200.0	345.0	79	175	254.0	-	133	26
420	210.0	420.0	90	180	262.0	-	137	32
510	240.0	510.0	100	215	316.0	-	172	38

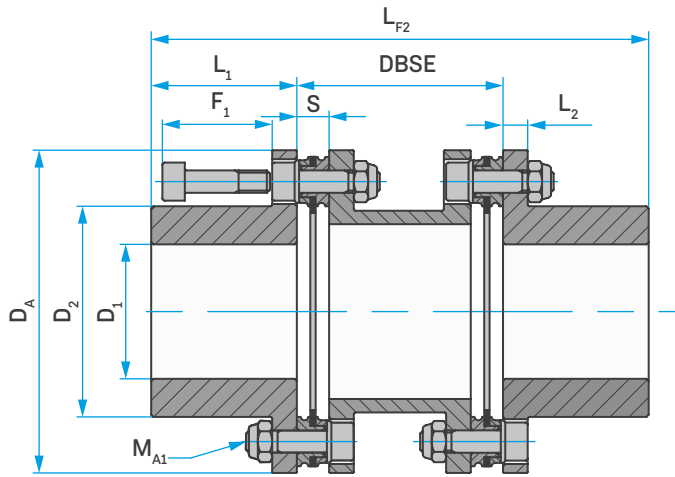

FD-C S : 标准

装配提示：

标准型号，预先钻孔或预先钻有滑键槽。键槽连接不适用于无间隙扭矩传递。可径向拆卸膜片组，无需移动轮毂。

联轴器大小	FD-C						FD-CL					
	M_{A1}		S	DBSE ¹⁾	L_{F1}	L_{F2}	M_{A1}		S	DBSE ¹⁾	L_{F1}	L_{F2}
	[-]	[Nm]	[mm]	[mm]	[mm]	[mm]	[-]	[Nm]	[mm]	[mm]	[mm]	[mm]
40	M3	1.5	2.9	16.0 26.0	36.9	50.0 60.0	-	-	-	-	-	-
53	M5	7.0	6.9	30.0 43.0	55.9	79.0 92.0	-	-	-	-	-	-
72	M5	8.0	7.5	31.2 60.0 100.0 140.0	86.5	110.2 139.0 179.0 219.0	M5	9.0	7.6	31.4 60.2 100.2 140.2	86.6	110.4 139.2 179.2 219.2
89	M6	14.0	8.8	37.6 70.0 80.0 100.0 140.0	98.8	127.6 160.0 170.0 190.0 230.0	M6	15.0	9.0	38.0 70.4 80.4 100.4 140.4	99.0	128.0 160.4 170.4 190.4 230.4
118	M8	31.0	10.4	46.3 100.0 140.0 180.0	120.4	156.3 210.0 250.0 290.0	M8	35.0	10.8	47.1 100.8 140.8 180.8	120.8	157.1 210.8 250.8 290.8
142	M10	62.0	12.0	55.0 100.0 140.0 180.0	132.0	175.0 220.0 260.0 300.0	M10	73.0	12.2	55.4 100.4 140.4 180.4	132.2	175.4 220.4 260.4 300.4
168	M12	110.0	13.0	62.6 100.0 140.0 180.0	163.0	212.6 250.0 290.0 330.0	M12	130.0	13.0	62.6 100.0 140.0 180.0	163.0	212.6 250.0 290.0 330.0
200	M14	180.0	15.0	140.0 180.0	195.0	320.0 360.0	M14	210.0	15.2	140.4 180.4	195.2	320.4 360.4
238	M16	280.0	20.8	140.0 180.0 250.0	270.8	390.0 430.0 500.0	M16	320.0	22.0	142.4 182.4 252.4	272.0	392.4 432.4 502.4
295	M20	540.0	28.0	200.0 250.0	348.0	520.0 570.0	M20	620.0	28.2	200.4 250.4	348.2	520.4 570.4
345	M24	950.0	32.2	224.0 250.0 300.0	432.2	624.0 650.0 700.0	M24	1000.0	32.4	224.4 250.4 300.4	432.4	624.4 650.4 700.4
420	M10	60.0	34.0	280.0	454.0	700.0	-	-	-	-	-	-
510	M12	105.0	46.8	350.0	526.8	830.0	-	-	-	-	-	-

i 1) 根据要求，DBSE 最高可达 3000 mm

FLEXDUR

型号 CA + CB

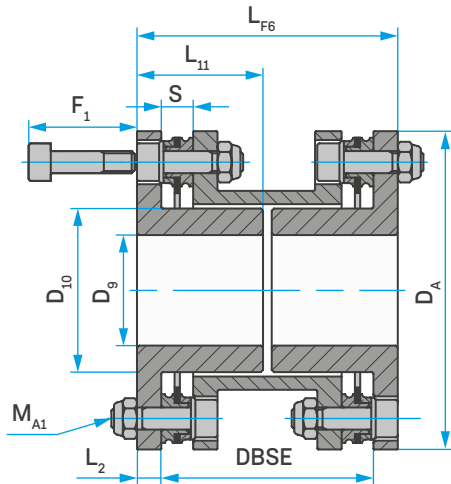

FD-C CA : 结构短小紧凑

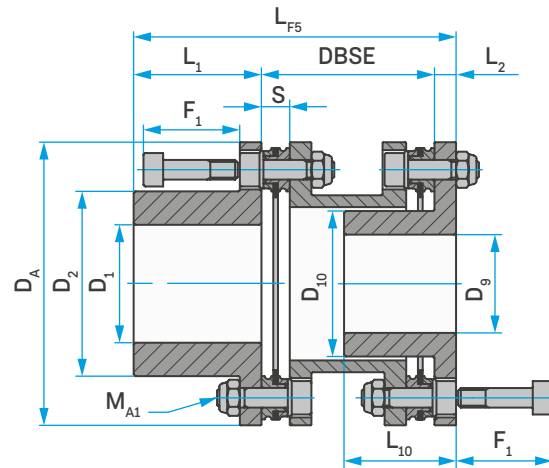

FD-C CB : 紧凑



联轴器数据

联轴器大小	L ₁	L ₃	L ₄	D _A	D _{1min} 预钻孔	D _{3min} 预钻孔	D _{1max}	D _{3max}	D ₂	D ₄	F ₁	L ₂
	[mm]	[mm]	[mm]	[mm]	[mm]	[mm]	[mm]	[mm]	[mm]	[mm]	[mm]	[mm]
53	24.5	24.5	24.5	53.0	6	6	22	17	32.5	24.5	24	5
72	39.5	39.5	34.5	70.5	10	10	32	25	47.0	37.0	24	5
		39.5	39.5									
		39.5	39.5									
89	45.0	45.0	40.0	88.0	14	14	42	32	62.5	48.0	32	8
		45.0	45.0									
		45.0	45.0									
		45.0	45.0									
118	55.0	55.0	55.0	116.5	15	15	55	44	82.0	64.0	40	10
		55.0	55.0									
		55.0	55.0									
142	60.0	60.0	58.0	140.5	19	19	65	50	98.0	77.0	47	11
		60.0	60.0									
		60.0	60.0									
168	75.0	75.0	60.0	166.5	25	25	80	60	118.0	90.5	55	12
		75.0	75.0									
		75.0	75.0									
200	90.0	90.0	81.0	198.5	30	30	95	75	141.0	114.0	64	14
		90.0	90.0									
		90.0	90.0									
238	125.0	125.0	-	238.0	39	39	115	90	169.0	135.0	81	16
		125.0	104.0									
		125.0	125.0									
295	160.0	160.0	-	295.0	59	59	140	115	205.0	170.0	112	22
		160.0	140.0									
		160.0	140.0									
345	200.0	200.0	-	345.0	79	79	175	120	254.0	180.0	133	26
		200.0	145.0									
		200.0	168.0									

 装配提示：

紧凑型号。预先钻孔或预先钻有滑键槽。键槽连接不适用于无间隙扭矩传递。

联轴器大小	FD-C						FD-CL					
	M _{A1}		S	DBSE ¹⁾	L _{F1}	L _{F2}	M _{A1}		S	DBSE ¹⁾	L _{F1}	L _{F2}
	[-]	[Nm]	[mm]	[mm]	[mm]	[mm]	[-]	[Nm]	[mm]	[mm]	[mm]	[mm]
53	M5	7.0	6.9	43	72.5	53	-	-	-	-	-	-
72	M5	8.0	7.5	60	104.5	70	M5	9.0	7.6	60.2	104.7	70.2
				100	144.5	110				100.2	144.7	110.2
				140	184.5	150				140.2	184.7	150.2
89	M6	14.0	8.8	70	123.0	86	M6	15.0	9.0	70.4	123.4	86.4
				80	133.0	96				80.4	133.4	96.4
				100	153.0	116				100.4	153.4	116.4
				140	193.0	156				140.4	193.4	156.4
118	M8	31.0	10.4	100	165.0	120	M8	35.0	10.8	100.8	165.8	120.8
				140	205.0	160				140.8	205.8	160.8
				180	245.0	200				180.8	245.8	200.8
142	M10	62.0	12.0	100	171.0	122	M10	73.0	12.2	100.4	171.4	122.4
				140	211.0	162				140.4	211.4	162.4
				180	251.0	202				180.4	251.4	202.4
168	M12	110.0	13.0	100	187.0	124	M12	130.0	13.0	100.0	187.0	124.0
				140	227.0	164				140.0	227.0	164.0
				180	267.0	204				180.0	267.0	204.0
200	M14	180.0	15.0	140	244.0	168	M14	210.0	15.2	140.4	244.4	168.4
				180	284.0	208				180.4	284.4	208.4
238	M16	280.0	20.8	140	281.0	-	M16	320.0	22.0	142.4	283.4	-
				180	321.0	212				182.4	323.4	214.4
				250	391.0	282				252.4	393.4	284.4
295	M20	540.0	28.0	200	382.0	-	M20	620.0	28.2	200.4	382.4	-
				250	432.0	294				250.4	432.4	294.4
345	M24	950.0	32.2	224	450.0	-	M24	1000.0	32.4	224.4	450.4	-
				250	476.0	302				250.4	476.4	302.4
				300	526.0	352				300.4	526.4	352.4

 1) 根据要求，DBSE 最高可达 3000 mm

FLEXDUR

型号 NO + SO

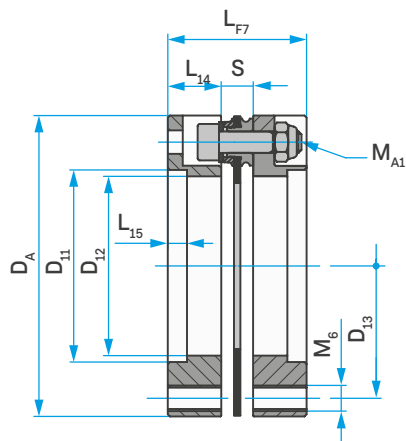

FD-C NO : 法兰版

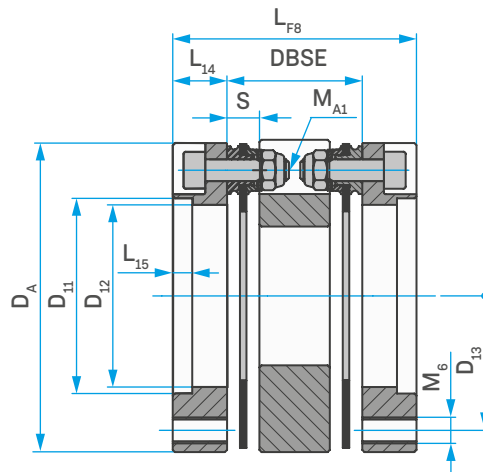

FD-C SO DBSE_{min} : 法兰版, 结构短小



联轴器数据

联轴器大小	L ₁ [mm]	D _A [mm]	D ₁ [mm]	D ₃ [mm]	L ₂ [mm]	M ₁ [mm]	D ₃ [mm]
72	12.5	70.5	45	42	4.5	6xM8	62
89	17.0	88.0	50	48	4.5	6xM8	75
118	22.0	116.5	75	72	5.0	6xM10	103
142	27.0	140.5	92	89	5.0	6xM12	116
168	31.0	166.5	105	100	5.0	6xM14	140
200	34.0	198.5	120	115	7.0	6xM16	175
238	41.0	238.0	140	135	7.0	6xM20	210
295	52.0	306.0	160	155	7.0	8xM24	240
345	64.0	360.0	180	175	7.0	8xM30	275

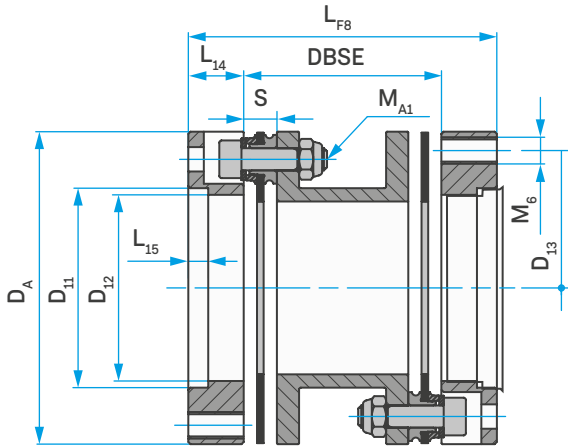

FD-C SO : 法兰版

装配提示：

法兰联轴器。只有在法兰轴向位移时才能拆卸膜片组。

针对相应的轮毂设计，可以脱离，无需移动设备部件，也无需松开系统螺栓，可以径向更换单元。

联轴器大小	FD-C						FD-CL					
	M _{A1} [-]	S [Nm]	DBSE ¹⁾ [mm]	L _{F1} [mm]	L _{F2} [mm]	M _{A1} [-]	S [mm]	DBSE ¹⁾ [mm]	L _{F1} [mm]	L _{F2} [mm]		
72	M5	8.0	7.5	32.5	31.2	56.2	M5	9.0	7.6	32.6	31.4	56.4
					60.0	85.0					60.2	85.2
					100.0	125.0					100.2	125.2
					140.0	165.0					140.2	165.2
89	M6	14.0	8.8	42.8	37.6	71.6	M6	15.0	9.0	43.0	38.0	72.0
					70.0	104.0					70.4	104.4
					80.0	114.0					80.4	114.4
					100.0	134.0					100.4	134.4
118	M8	31.0	10.4	54.4	46.3	90.3	M8	35.0	10.8	54.8	47.1	91.1
					100.0	144.0					100.8	144.8
					140.0	184.0					140.8	184.8
					180.0	224.0					180.8	224.8
142	M10	62.0	12.0	66.0	55.0	109.0	M10	73.0	12.2	66.2	55.4	109.4
					100.0	154.0					100.4	154.4
					140.0	194.0					140.4	194.4
					180.0	234.0					180.4	234.4
168	M12	110.0	13.0	75.0	62.6	124.6	M12	130.0	13.0	75.0	62.6	124.6
					100.0	162.0					100.0	162.0
					140.0	202.0					140.0	202.0
					180.0	242.0					180.0	242.0
200	M14	180.0	15.0	83.0	140.0	208.0	M14	210.0	15.2	83.2	140.4	208.4
					180.0	248.0					180.4	248.4
238	M16	280.0	20.8	102.8	140.0	222.0	M16	320.0	22.0	104.0	142.4	224.4
					180.0	262.0					182.4	264.4
					250.0	332.0					252.4	334.4
295	M20	540.0	28.0	132.0	200.0	304.0	M20	620.0	28.2	132.2	200.4	304.4
					250.0	354.0					250.4	354.4
345	M24	950.0	32.2	160.2	224.0	352.0	M24	1000.0	32.4	160.4	224.4	352.4
					250.0	378.0					250.4	378.4
					300.0	428.0					300.4	428.4

¹⁾ 根据要求，DBSE 最高可达 3000 mm

FLEXDUR

型号 NX + SX

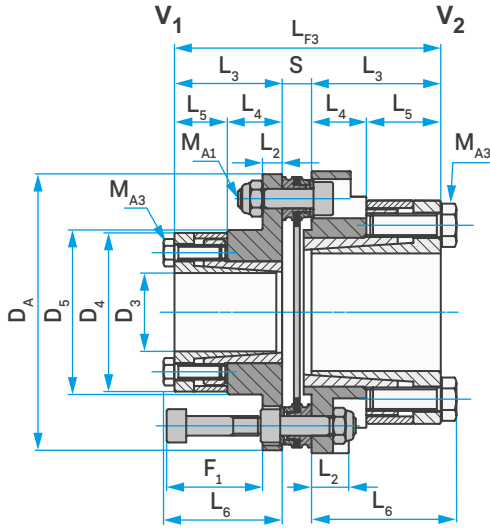

FD-C NX : 带内部锁紧装置

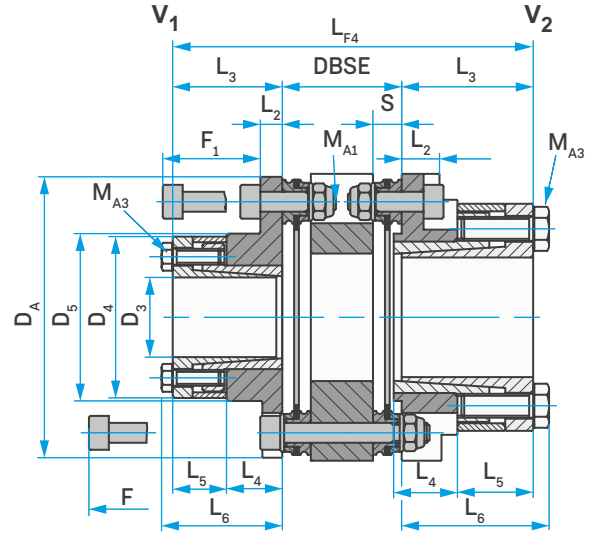

FD-C SX DBSE_{min} : 带内部锁紧装置, 结构短小

联轴器数据

联轴器大小	型号	D _A [mm]	L ₂ [mm]	F [mm]	F ₁ [mm]	L ₁ [mm]	L ₃ [mm]	L ₄ [mm]	L ₅ [mm]	D ₂ [mm]	D ₃ [mm]	M _{A2} [-]	M _{A2} [Nm]
53 + 145	V2	53.0	9.5	-	-	25.5	14.0	13.5	28.5	40.5	42	M4	5
72 + 145	V1	70.5	5.0	43	25	27.5	14.0	13.5	30.5	40.5	42	M4	5
72 + 330	V2	70.5	10.0	-	-	33.0	14.0	19.0	37.0	57.0	58	M6	17
89 + 500	V1	88.0	8.0	53	32	44.5	27.0	19.0	48.5	57.0	60	M6	17
89 + 920	V2	88.0	15.0	-	-	44.5	25.5	19.0	48.5	70.5	72	M6	17
118 + 1140	V1	116.5	10.0	67	40	35.0	16.5	18.5	39.0	74.0	80	M6	17
118 + 1370	V2	116.5	19.0	-	-	44.0	27.0	19.0	50.0	89.5	92	M6	17
142 + 920	V1	140.5	11.0	82	47	45.5	26.5	19.0	50.0	70.5	72	M6	17
142 + 2820	V1	140.5	11.0	82	47	59.5	36.5	23.0	65.0	96.5	98	M8	41
168 + 2820	V1	166.5	12.0	94	55	59.5	36.5	23.0	65.0	96.5	98	M8	41
200 + 2820	V1	198.5	14.0	-	64	59.5	36.5	23.0	65.0	96.5	98	M8	41

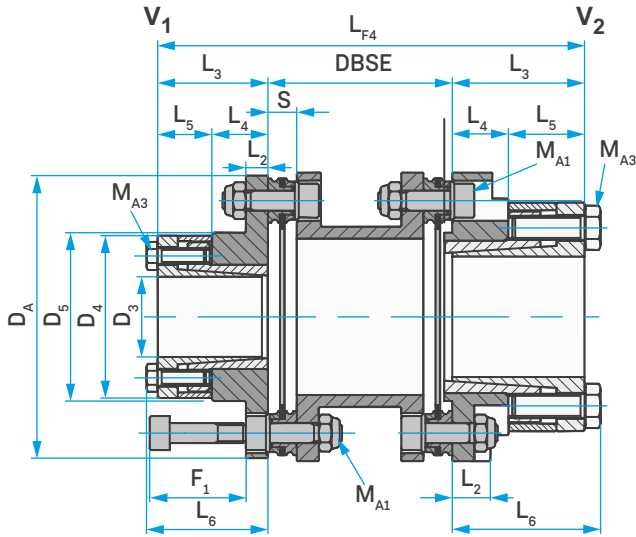

FD-C SX : 带内部锁紧装置

装配提示：

带内部锁紧装置的轮毂。

无间隙扭矩传递。

V₁：可径向拆卸膜片组，无需移动轮毂。

V₂：可以在松开和轴向移动夹紧装置后径向拆卸膜片组。

联轴器大小	FD-C						FD-CL							
	M _{A1}		S	DBSE	L _{F1}	L _{F2}	M _{A1}		S	DBSE	L _{F1}	L _{F2}		
	[-]	[Nm]					[-]	[Nm]						
53 + 145	M5	7.0	6.9	30.0	57.9	81.0	-	-	-	-	-	-		
				43.0		94.0								
72 + 145	M5	8.0	7.5	31.2	62.5	86.2	M5	9.0	7.6	-	62.6	86.4		
				60.0		115.0						60.2	115.2	
				100.0		155.0						100.2	155.2	
				140.0		195.0						140.2	195.2	
				140.0		195.0						140.2	195.2	
72 + 330	M5	8.0	7.5	31.2	73.5	97.2	M5	9.0	7.6	-	73.6	97.4		
				60.0		126.0						60.2	126.2	
				100.0		166.0						100.2	166.2	
				140.0		206.0						140.2	206.2	
				140.0		206.0						140.2	206.2	
89 + 500	M6	14.0	8.8	37.6	97.8	126.6	M6	15.0	9.0	-	98.0	127.0		
				70.0		159.0						70.4	159.4	
				80.0		169.0						80.4	169.4	
				100.0		189.0						100.4	189.4	
				140.0		229.0						140.4	229.4	
89 + 920	M6	14.0	8.8	37.6	97.8	126.6	M6	15.0	9.0	-	98.0	127.0		
				70.0		159.0						70.4	159.4	
				80.0		169.0						80.4	169.4	
				100.0		189.0						100.4	189.4	
				140.0		229.0						140.4	229.4	
118 + 1140	M8	31.0	10.4	46.3	80.4	116.3	M8	35.0	10.8	-	80.8	117.1		
				100.0		170.0						100.8	170.4	
				140.0		210.0						140.8	210.4	
				180.0		250.0						180.8	250.4	
				180.0		250.0						180.8	250.4	
118 + 1370	M8	31.0	10.4	46.3	98.4	134.3	M8	35.0	10.8	-	98.8	135.1		
				100.0		188.0						100.8	188.4	
				140.0		228.0						140.8	228.4	
				180.0		268.0						180.8	268.4	
				180.0		268.0						180.8	268.4	
142 + 920	M10	62.0	12.0	55.0	103.0	146.0	M10	73.0	12.2	-	103.2	146.4		
				100.0		191.0						100.4	191.4	
				140.0		231.0						140.4	231.4	
				180.0		271.0						180.4	271.4	
				180.0		271.0						180.4	271.4	
142 + 2820	M10	62.0	12.0	55.0	131.0	174.0	M10	73.0	12.2	-	131.2	174.4		
				100.0		219.0						100.4	219.4	
				140.0		259.0						140.4	259.4	
				180.0		299.0						180.4	299.4	
				180.0		299.0						180.4	299.4	
168 + 2820	M12	110.0	13.0	62.6	132.0	181.6	M12	130.0	-	-	-	-		
				100.0		219.0							100.4	219.4
				140.0		259.0							140.4	259.4
				180.0		299.0							180.4	299.4
200 + 2820	M14	180.0	15.0	140.0	134.0	259.0	M14	210.0	-	-	-	-		
				180.0		299.0							180.4	299.4

型号 NX - SX 首选孔 [mm] / 轴公差 h8 的夹紧装置的可传递扭矩 [Nm]

尺寸	D ₁	11	12	14	15	16	18	19	20	22	24	25	28	30	32	35	38	40	42	45	48	50	55	60	
145	[Nm]	50	55	90	95	115	130	140	145	-	-	-	-	-	-	-	-	-	-	-	-	-	-	-	
330	[Nm]	-	-	-	-	-	-	195	200	240	265	275	310	330	-	-	-	-	-	-	-	-	-	-	
500	[Nm]	-	-	-	-	-	-	310	330	360	400	410	460	500	-	-	-	-	-	-	-	-	-	-	
920	[Nm]	-	-	-	-	-	-	-	-	-	470	490	550	590	700	770	840	880	920	-	-	-	-	-	
1140	[Nm]	-	-	-	-	-	-	-	-	-	-	-	-	-	540	710	780	820	950	1020	1090	1140	-	-	
1370	[Nm]	-	-	-	-	-	-	-	-	-	-	-	-	-	-	-	-	-	-	-	-	-	1250	1370	
2820	[Nm]	-	-	-	-	-	-	-	-	-	-	-	-	1240	1330	1420	1550	1780	1880	1970	2110	2250	2350	2590	2820

FLEXDUR

型号 NZ + SZ

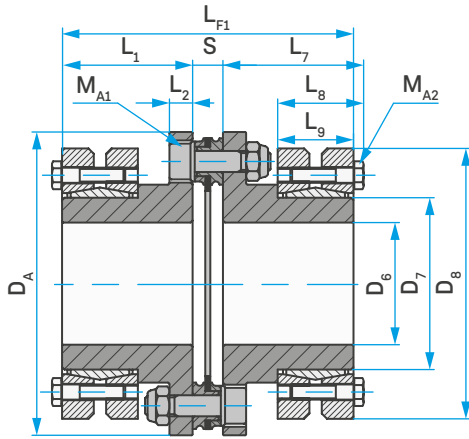

FD-C NZ : 带外夹紧件

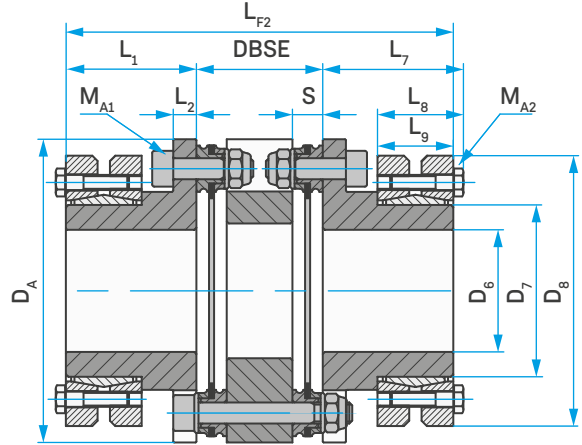

FD-C SZ DBSE_{min} : 带外夹紧件, 结构短小



联轴器数据

联轴器大小	D ₂	L ₁	L ₃	D _A	D ₁ ²⁾	L ₂	D ₃	L ₄	L ₅	M _{A2}		TL 扭矩受限
	[mm]	[mm]	[mm]							[mm]	[-]	
89	30	45.0	48.5	88.0	24-25-26	8	60	24.5	21	M5	6	310-340-380
	36		49.0		28-30-31		72	27.0	23	M6	12	460-590-630
	44		49.0		32-35-36		80	29.0	25	M6	12	630-780-860
	50		49.0		38-40-42		90	31.0	27	M6	12	940-1 100-1 300
118	50	55.0	59.0	116.5	38-40-42	10	90	31.0	27	M6	12	940-1 100-1 300
	55		59.0		42-45-48		100	34.0	30	M6	12	1200-1500-1 900
	75		60.5		50-55-60-65		138	37.5	32	M8	30	2 000-2 500-3 200-3 900
142	68	60.0	64.0	140.5	50-55-60	11	115	34.0	30	M6	12	2 000-2 500-3 100
	90	63.5	69.0		65-70-75		155	44.5	39	M8	30	4 700-6 000-7 200
168	68	75.0	79.0	166.5	50-55-60	12	110	34.0	30	M6	12	2 000-2 500-3 100
	90	75.0	80.5		65-70-75		155	44.5	39	M8	30	4 700-6 000-7 200
	115	80.5	87.0		80-85-90		188	56.5	50	M10	59	8 500-10 000-12 000
200	68	90.0	94.0	198.5	50-55-60	14	110	34.0	30	M6	12	2 000-2 500-3 100
	90		95.5		65-70-75		155	44.5	39	M8	30	4 700-6 000-7 200
	115		96.5		80-85-90		188	56.5	50	M10	59	8 500-10 000-12 000
	130		97.0		90-95-100-110		215	59.0	52	M10	59	13 700-15 800-18 200-23 500
238	100	125.0	130.5	238.0	70-75-80	16	170	49.5	44	M8	30	6 900-7 500-9 000
	130	125.0	132.0		90-95-100-110		215	59.0	52	M10	59	13 700-15 800-18 200-23 500
	155	125.0	132.5		105-110-115-120		265	71.5	64	M12	100	20 000-23 000-26 000-29 500
	165	129.0	139.0		115-120-125-135		290	81.0	71	M16	250	36 000-39 000-44 000-51 200
295	130	160.0	167.0	295.0	90-95-100-110	22	215	59.0	52	M10	59	13 700-15 800-18 200-23 500
	160		167.5		110-115-120-125		265	71.5	64	M12	100	22 500-25 500-28 600-33 000
	175		170.0		125-130-135-140		300	81.0	71	M16	250	40 000-44 000-49 000-52 500
	185		170.0		130-140-145-150		330	96.0	86	M16	250	50 000-55 000-60 000-65 000
	195		170.0		140-150-155-165		350	96.0	86	M16	250	66 000-76 000-82 000-96 000
345	170	200.0	210.0	345.0	120-125-130-135	26	290	81.0	71	M16	250	31 700-35 800-40 000-45 000
	195		210.0		140-150-155-165		350	96.0	86	M16	250	66 000-76 000-82 000-96 000
	220		210.0		160-165-170-180		370	114.0	104	M16	250	95 000-102 000-110 000-128 000
	250		212.5		180-190-200-210		405	120.5	108	M16	250	160 000-180 000-200 000-212 000
	195		220.0		140-150-155-165		350	96.0	86	M16	250	66 000-76 000-82 000-96 000
420	220	210.0	220.0	420.0	160-165-170-180	32	370	114.0	104	M16	250	95 000-102 000-110 000-128 000
	260		222.5		180-190-200-220		430	132.5	120	M20	490	165 000-185 000-204 000-214 000
	220		250.0		160-165-170-180		370	114.0	104	M16	250	95 000-102 000-110 000-128 000
	260		252.5		180-190-200-220		430	132.5	120	M16	250	165 000-185 000-204 000-214 000
510	300	240.0	260.0	510.0	230-240-250-260	38	485	142.0	122	M20	490	274 000-296 000-316 000-364 000

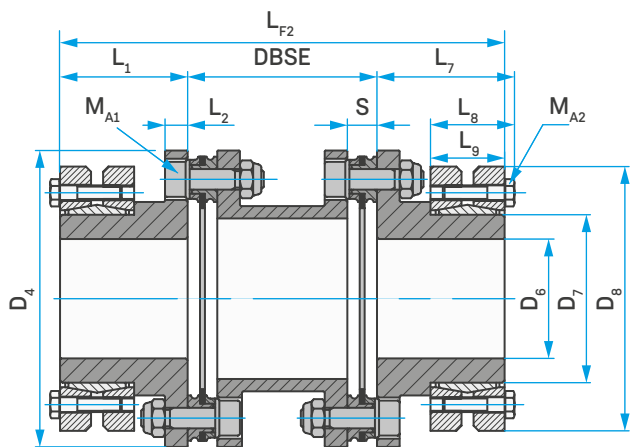

FD-C SZ : 带外夹紧件

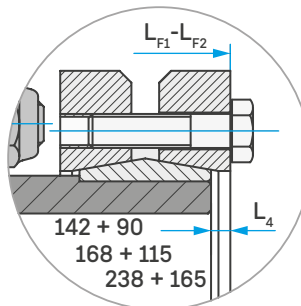

装配提示 :

带外夹紧件的轮毂。无间隙扭矩传递。可以在松开和轴向移动夹紧装置后径向拆卸膜片组。

联轴器大小	FD-C						FD-CL							
	M _{A1} [-]	M _{A1} [Nm]	S [mm]	DBSE ¹⁾ [mm]	L _{F1} [mm]	L _{F2} [mm]	M _{A1} [-]	M _{A1} [Nm]	S [mm]	DBSE ¹⁾ [mm]	L _{F1} [mm]	L _{F2} [mm]		
89	M6	14.0	8.8	37.6	98.8	127.6	M6	15.0	9.0	-	38.0	128.0		
				70.0		160.0					70.4	160.4		
				80.0		170.0					80.4	170.4		
				100.0		190.0					100.4	190.4		
				140.0		230.0					140.4	230.4		
118	M8	31.0	10.4	46.3	100.4	156.3	M8	35.0	10.8	-	47.1	157.1		
				100.0		210.0					100.8	210.4		
				140.0		250.0					140.8	250.4		
				180.0		290.0					180.8	290.4		
				180.0		290.0					180.8	290.4		
142	M10	62.0	12.0	55.0	132.0	175.0	M10	73.0	12.2	-	55.4	175.4		
				100.0		220.0					100.4	220.4		
				140.0		260.0					140.4	260.4		
				180.0		300.0					180.4	300.4		
				180.0		300.0					180.4	300.4		
				55.0	139.0	182.0 ³⁾					139.2	55.4	182.4	
				100.0		227.0 ³⁾						100.4	227.4 ³⁾	
				140.0		267.0 ³⁾						140.4	267.4 ³⁾	
				180.0		307.0 ³⁾						180.4	307.4 ³⁾	
				180.0		307.0 ³⁾						180.4	307.4 ³⁾	
168	M12	110.0	13.0	62.6	163.0	216.6	M12	130.0	13.0	-	62.6	216.6		
				100.0		250.0					100.0	250.0		
				140.0		290.0					140.0	290.0		
				180.0		320.0					180.0	320.0		
				100.0		174.0					261.0 ⁴⁾	174.0	100.0	261.0 ⁴⁾
				140.0							301.0 ⁴⁾		140.0	301.0 ⁴⁾
				180.0							341.0 ⁴⁾		180.0	341.0 ⁴⁾
200	M14	180.0	15.0	140.0	195.0	320.0	M14	210.0	15.2	-	140.4	320.4		
				180.0		360.0					180.4	360.4		
238	M16	280.0	20.8	140.0	270.8	390.0	M16	320.0	22.0	-	142.4	392.4		
				180.0		430.0					182.4	432.4		
				250.0		500.0					252.4	502.4		
				140.0	278.8	398.0 ⁵⁾					280.0	142.4	400.4 ⁵⁾	
				180.0		438.0 ⁵⁾						182.4	440.4 ⁵⁾	
				250.0		508.0 ⁵⁾						252.4	510.4 ⁵⁾	
295	M20	540.0	28.0	200.0	348	520.0	M20	620.0	28.2	-	200.4	520.4		
				250.0		570.0					250.4	570.4		
345	M24	950.0	32.2	224.0	432.2	624.0	M24	1000.0	32.4	-	224.4	624.4		
				250.0		650.0					250.4	650.4		
				300.0		700.0					300.4	700.4		
420	M10	60.0	34.0	280.0	454.0	700.0	-	-	-	-	-	-		
510	M12	105.0	46.8	350.0	526.8	830.0	-	-	-	-	-	-		

1) 根据要求, DBSE 最高可达 3000 mm 2) 轴和轮毂的适配公差: Ø 24 - Ø 30 = H6-j6 / Ø 30 - Ø 50 = H6-h6 / Ø 50 - Ø 80 = H6-g6 / Ø 80 - Ø 260 = H7-g6 3) L₆=3.5 - 4) L₆=5.5 - 5) L₆=4

FLEXDUR

型号 F

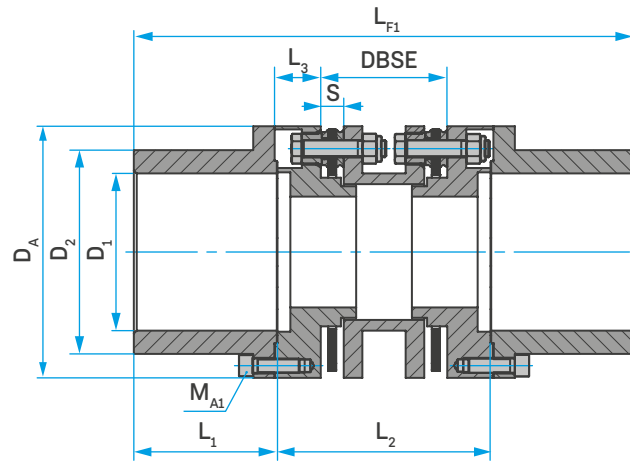

FD-C F : API 610 + 671



联轴器数据

联轴器大小	L_1 [mm]	D_A [mm]	D_{1min} 预钻孔 [mm]	D_{1max} [mm]	D_2 [mm]	L_3 [mm]
89	50	94	14	50	69	20
118	70	121	14	70	91	23
142	80	148	19	80	112	26
168	100	176	24	105	135	32.5
200	120	202	29	120	160	37
238	140	250	39	140	192	43.5
295	180	302	59	180	240	50.5
345	200	352	79	220	285	64.5

装配提示：

特殊型号符合 API 610/671 要求。

联轴器单元可以径向拆卸而无需机组或松开膜片组。

用于在膜片断裂时固定过渡件的止动装置。

联轴器大小	FD-C						FD-CL					
	M _{A1}		S [mm]	DBSE ¹⁾ [mm]	L ₂ ¹⁾ [mm]	L _{F1} [mm]	M _{A1}		S [mm]	DBSE ¹⁾ [mm]	L ₂ ¹⁾ [mm]	L _{F1} [mm]
	[-]	[Nm]					[-]	[mm]				
89	M6	17	8.8	50	88	188	M6	17	9.0	50.4	88.4	188.4
				62	100	200				62.4	100.4	200.4
				102	140	240				102.4	140.4	240.4
118	M8	41	10.4	61	105	245	M8	41	10.8	61.8	105.8	245.8
				96	140	280				96.8	140.8	280.8
				136	180	320				136.8	180.8	320.8
142	M8	41	12	63	112	272	M8	41	12.2	63.4	112.4	272.4
				91	140	300				91.4	140.4	300.4
				131	180	340				131.4	180.4	340.4
168	M10	83	13	74	135	335	M10	83	13.0	74.0	135.0	335.0
				119	180	380				119.0	180.0	380.0
				189	250	450				189.0	250.0	450.0
200	M12	145	15	90	160	400	M12	145	15.2	90.4	160.4	400.4
				110	180	420				110.4	180.4	420.4
				180	250	490				180.4	250.4	490.4
238	M16	355	20.8	105.4	188	468	M16	355	22.0	107.8	190.4	470.4
				167.4	250	530				169.8	252.4	532.4
				217.4	300	580				219.4	302.4	582.0
295	M16	355	28	138	235	595	M16	355	28.2	138.4	235.4	595.4
				153	250	610				153.4	250.4	610.4
				203	300	660				203.4	300.4	660.4
345	M20	690	32.2	155	278	678	M20	690	32.4	155.4	278.4	678.4
				177	300	700				177.4	300.4	700.4
				227	350	750				227.4	350.4	750.4

i 1) 根据要求，DBSE 最高可达 3000 mm

FLEXDUR

型号 NY + SY

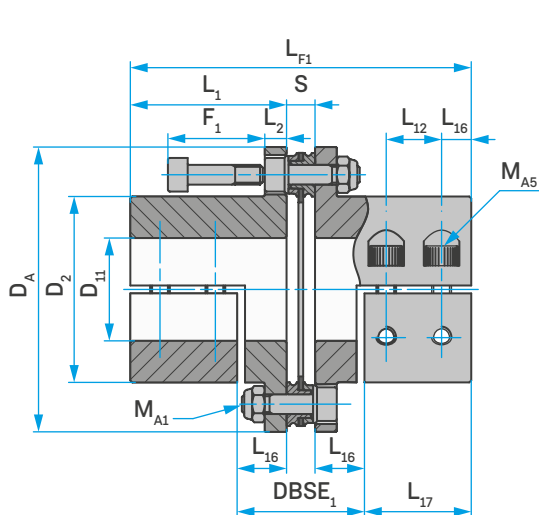

FD-C NY：带夹紧轮毂，分两部分

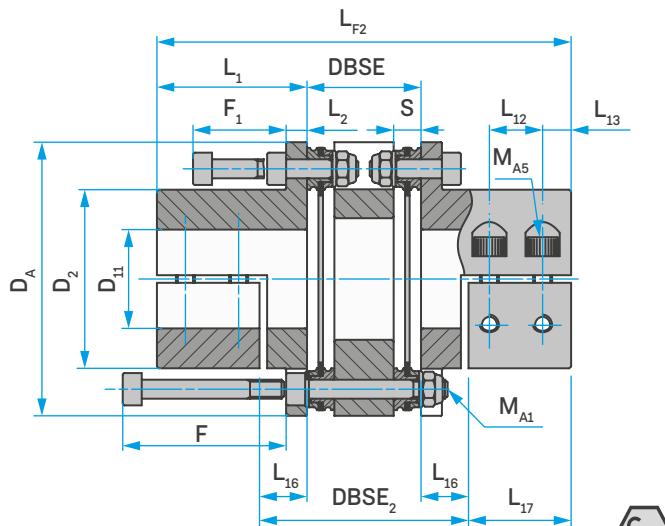

FD-C SY DBSE_{min}：带夹紧轮毂，分两部分，结构短小



联轴器数据

联轴器大小	L ₁	D _A	D ₂	F	F ₁	L ₂	M _{A2}		L ₄	L ₅	L ₃	L ₆
	[mm]	[mm]	[mm]	[mm]	[mm]	[mm]	[-]	[Nm]	[mm]	[mm]	[mm]	[mm]
72	39.5	70.5	47.0	43.0	24.0	5.0	M6	17.0	7.5	12.5	13.0	27.0
							M5	9.7				
89	45.0	88.0	62.5	53.0	32.0	8.0	M8	41.0	8.0	17.5	14.0	27.5
							M6	17.0				
118	55.0	116.5	82.0	67.0	40.0	10.0	M10	83.0	10.0	21.0	17.0	34.0
							M8	41.0				
142	60.0	140.5	98.0	82.0	47.0	11.0	M10	83.0	10.0	25.0	18.5	35.0
168	75.0	166.5	118.0	94.0	55.0	12.0	M12	145.0	13.0	30.0	23.0	45.0

型号 NY - SY 首选孔 [mm] / 轴公差 h7 的夹紧装置的可传递扭矩 [Nm]，无滑键

尺寸	D ₁ 最大																				M _{A2}						
	15	16	18	19	20	22	24	25	28	30	32	35	38	40	42	45	48	50	55	60	65	70	75	80	[-]	[Nm]	
72	130	140	155	165	175	190	210	220	-	-	-	-	-	-	-	-	-	-	-	-	-	-	-	-	M6	17.0	
	-	-	-	-	-	-	-	-	170	185	-	-	-	-	-	-	-	-	-	-	-	-	-	-	-	M5	9.7
89	-	-	-	-	320	350	385	400	450	480	515	560	-	-	-	-	-	-	-	-	-	-	-	-	-	M8	41.0
	-	-	-	-	-	-	-	-	-	-	-	-	335	350	-	-	-	-	-	-	-	-	-	-	-	M6	17.0
118	-	-	-	-	-	-	-	-	-	780	835	910	990	1040	1095	1175	-	-	-	-	-	-	-	-	-	M10	83.0
	-	-	-	-	-	-	-	-	-	-	-	-	-	-	-	770	805	885	-	-	-	-	-	-	-	M8	41.0
142	-	-	-	-	-	-	-	-	-	780	835	910	990	1040	1095	1175	1250	1305	1435	1565	1700	-	-	-	M10	83.0	
168	-	-	-	-	-	-	-	-	-	-	-	-	1350	1470	1545	1625	1740	1855	1935	2125	2320	2515	2700	2900	3095	M12	145

M_{A2} [Nm] = 夹紧螺栓的扭矩

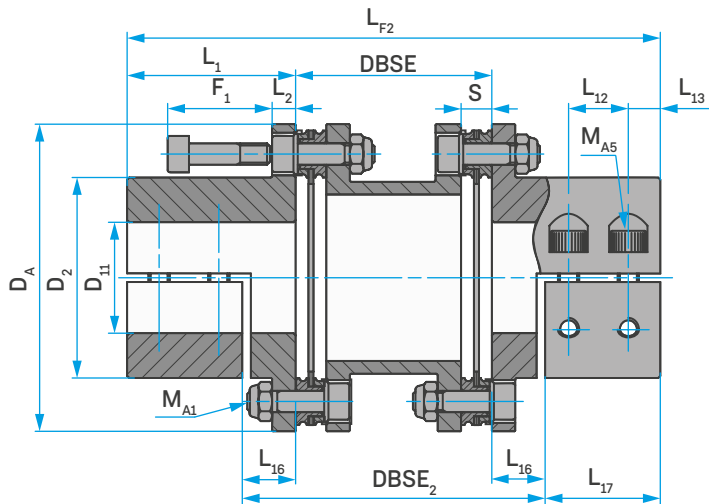

FD-C SY：带夹紧轮毂，分两部分

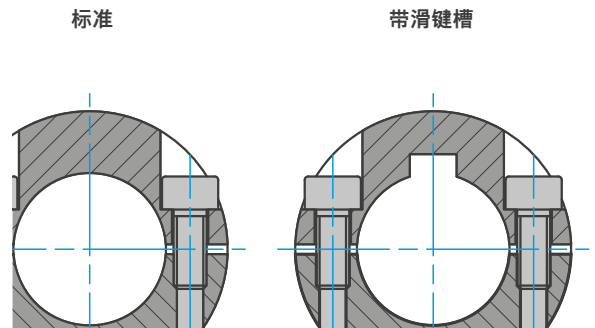

装配提示：

夹紧毂，分两部分。可选择带滑键槽的孔。
无间隙扭矩传递。可径向拆卸膜片组，无需移动轮毂。联轴器可以径向拆卸而无需机组或松开膜片组。

联轴器大小	FD-C								FD-CL							
	MA1		S	DBSE ¹⁾	DBSE ₁	LF ₁	DBSE ₂	LF ₂	MA1		S	DBSE ¹⁾	DBSE ₁	LF ₁	DBSE ₂	LF ₂
	[-]	[Nm]	[mm]	[mm]	[mm]	[mm]	[mm]	[mm]	[-]	[Nm]	[mm]	[mm]	[mm]	[mm]	[mm]	[mm]
72	M5	8	7.5	31.2	32.5	86.5	56.2	110.2	M5	9	7.6	31.4	32.6	86.6	56.4	110.4
				60.0			85.0	139.0				60.2			85.2	139.2
				100.0			125.0	179.0				100.2			125.2	179.2
				140.0			165.0	219.0				140.2			165.2	219.2
89	M6	14	8.8	37.6	43.8	98.8	72.6	127.6	M6	15	9.0	38.0	44.0	99.0	73.0	128.0
				70.0			105.0	160.0				70.4			105.4	160.4
				80.0			115.0	170.0				80.4			115.4	170.4
				100.0			135.0	190.0				100.4			135.4	190.4
118	M8	31	10.4	46.3	52.4	120.4	88.3	156.3	M8	35	10.8	47.1	52.8	120.8	89.1	157.1
				100.0			142.0	210.0				100.8			142.8	210.8
				140.0			182.0	250.0				140.8			182.8	250.8
				180.0			222.0	290.0				180.8			222.8	290.8
142	M10	62	12.0	55.0	62.0	132.0	105.0	175.0	M10	73	12.2	55.4	62.2	132.2	105.4	175.4
				100.0			150.0	220.0				100.4			150.4	220.4
				140.0			190.0	260.0				140.4			190.4	260.4
				180.0			230.0	300.0				180.4			230.4	300.4
168	M12	110	13.0	62.6	73.0	163.0	122.6	212.6	M12	130	13.0	62.6	73.0	163.0	-	212.6
				100.0			160.0	250.0				100.0			160.0	250.0
				140.0			200.0	290.0				140.0			200.0	290.0
				180.0			240.0	330.0				180.0			240.0	330.0

i 1) 根据要求，DBSE 最高可达 3000 mm

FLEXDUR

型号 NK + SK

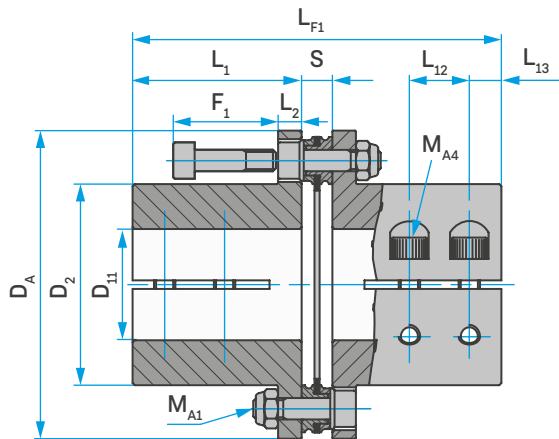

FD-C NK : 带夹紧轮毂，开槽

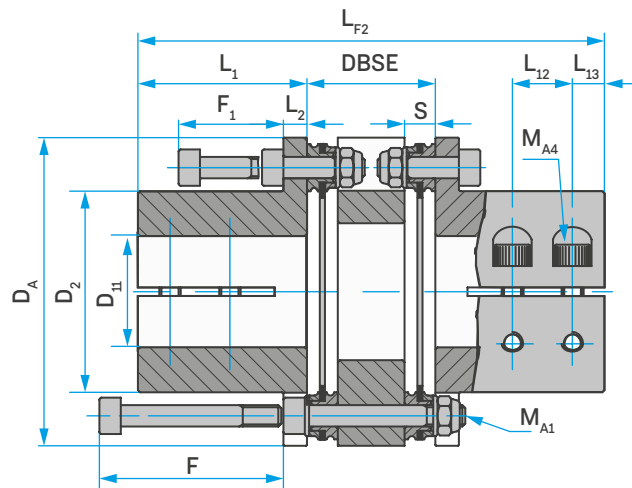

FD-C SK DBSE_{min} : 带夹紧轮毂，分两部分，结构短小

联轴器数据

联轴器大小	L ₁ [mm]	D _A [mm]	D ₂ [mm]	F [mm]	F ₁ [mm]	L ₂ [mm]	M _{A2}		L ₃ [mm]	L ₄ [mm]
							[-]	[Nm]		
40	17.0	40.0	26.0	25.0	15.0	4.0	M4	5.2	-	4.5
							M3	2.6		
53	24.5	53.0	32.5	43.0	24.0	5.0	M4	5.2	9.0	5.0
72	39.5	70.5	47.0	43.0	24.0	5.0	M6	17.0	13.0	7.5
89	45.0	88.0	62.5	53.0	32.0	8.0	M8	41.0	16.0	9.0
118	55.0	116.5	82.0	67.0	40.0	10.0	M10	83.0	19.5	10.5
142	60.0	140.5	98.0	82.0	47.0	11.0	M10	83.0	20.0	11.5

型号 NK - SK 首选孔 [mm] / 轴公差 h7 的夹紧装置的可传递扭矩 [Nm] 无滑键

尺寸	D ₁ 最大																				M _{A2}						
	8	10	11	12	14	15	16	18	19	20	22	24	25	28	30	32	35	38	40	42	45	48	50	55	60	[-]	[Nm]
40	9	12	12	12	-	-	-	-	-	-	-	-	-	-	-	-	-	-	-	-	-	-	-	-	-	M4	5.2
	-	-	-	-	12	15	-	-	-	-	-	-	-	-	-	-	-	-	-	-	-	-	-	-	-	M3	2.6
53	-	-	-	50	55	60	70	82	95	100	-	-	-	-	-	-	-	-	-	-	-	-	-	-	-	M4	5.2
72	-	-	-	-	-	65	75	90	100	115	140	170	180	-	-	-	-	-	-	-	-	-	-	-	-	M6	17.0
89	-	-	-	-	-	-	-	-	-	120	150	180	210	250	300	350	360	-	-	-	-	-	-	-	-	M8	41.0
118	-	-	-	-	-	-	-	-	-	-	-	-	-	-	360	420	490	550	650	720	790	-	-	-	-	M10	83.0
142	-	-	-	-	-	-	-	-	-	-	-	-	-	-	340	380	420	470	500	600	650	750	900	1200	1450	M10	83.0

M_{A2} [Nm] = 夹紧螺栓的扭矩

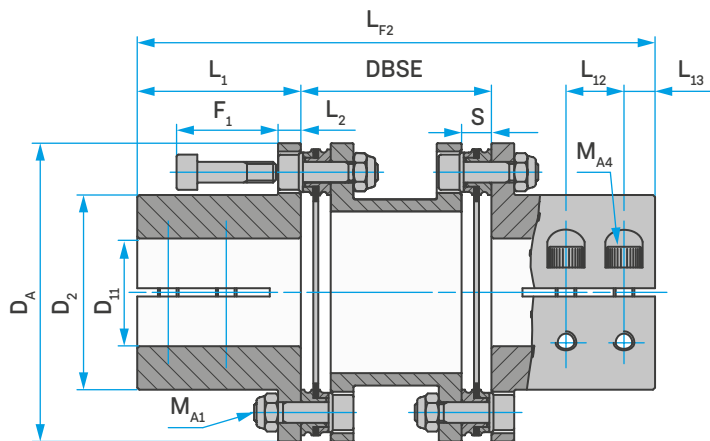

FD-C SK : 带夹紧轮毂，开槽

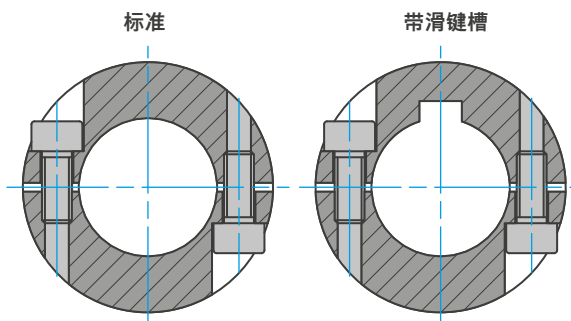

装配提示：

- 夹紧毂，开槽。可选择带滑键槽的孔。
- 无间隙扭矩传递。
- 可径向拆卸膜片组，无需移动轮毂。

联轴器大小	FD-C						FD-CL					
	M _{A1}		S	DBSE ¹⁾	L _{F1}	L _{F2}	M _{A1}		S	DBSE ¹⁾	L _{F1}	L _{F2}
	[-]	[Nm]	[mm]	[mm]	[mm]	[mm]	[-]	[Nm]	[mm]	[mm]	[mm]	[mm]
40	M3	1.5	2.9	16.0	36.9	50.0	-	-	-	-	-	-
				26.0		60.0						
53	M5	7.0	6.9	30.0	55.9	79.0	-	-	-	-	-	-
				43.0		92.0						
72	M5	8.0	7.5	31.2	86.5	110.2	M5	9	7.6	31.4	86.6	110.4
				60.0		139.0				60.2		139.2
				100.0		179.0				100.2		179.2
				140.0		219.0				140.2		219.2
89	M6	14.0	8.8	37.6	98.8	127.6	M6	15	9.0	38.0	99.0	128.0
				70.0		160.0				70.4		160.4
				80.0		170.0				80.4		170.4
				100.0		190.0				100.4		190.4
118	M8	31.0	10.4	46.3	120.4	156.3	M8	35	10.8	47.1	120.8	157.1
				100.0		210.0				100.8		210.8
				140.0		250.0				140.8		250.8
				180.0		290.0				180.8		290.8
142	M10	62.0	12.0	55.0	132.0	175.0	M10	73	12.2	55.4	132.2	175.4
				100.0		220.0				100.4		220.4
				140.0		260.0				140.4		260.4
				180.0		300.0				180.4		300.4

i 1) 根据要求，DBSE 最高可达 3000 mm

FLEXDUR

型号 SP-CA + SP-CB

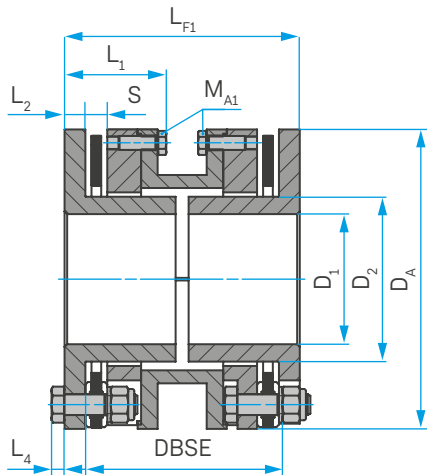

FD-C SP-CA：结构短小紧凑，分离式过渡件

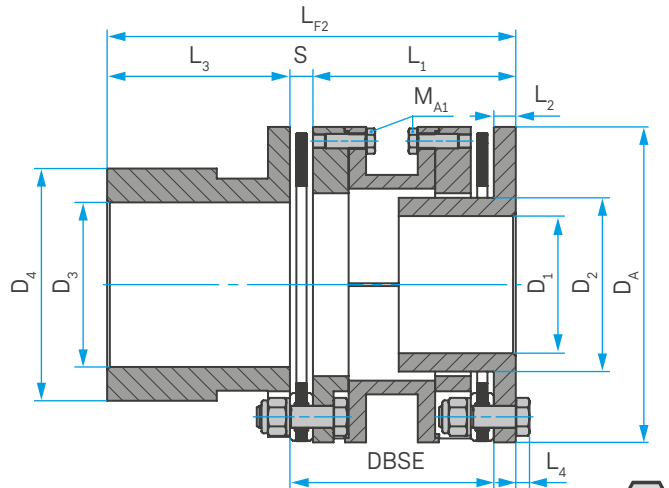

FD-C SP-CB：紧凑，分离式过渡件



联轴器数据

联轴器大小	L ₁ [mm]	L ₃ [mm]	D _A [mm]	D _{1max} [mm]	D _{3max} [mm]	D ₂ [mm]	D ₄ [mm]	L ₂ [mm]	L ₄ [mm]
89	45	45	88	35	45 ¹⁾	48	58	7	4
118	45	55	116.5	50	60	64	81	8	5.5
142	53	60	140.5	60	70	77	94	9	7
168	64	75	166.5	75 ¹⁾	90	93	115	11	8
200	71	90	198.5	90 ¹⁾	110 ¹⁾	114	136	12.5	9
238	82	125	238	100	120	135	169	14.5	10
295	112	160	295	130	150	170	205	19	13
345	128	200	345	150 ¹⁾	180	190	254	24	15

¹⁾ D_{1max} - D_{3max} 带有符合 DIN 6885/3 标准的滑键槽

 装配提示：

带有分离式过渡件的紧凑型号。

预先钻孔或预先钻有滑键槽。

特殊设计实现无需移动轮毂或拆卸膜片组即可维护联轴器。

联轴器大小	FD-C						FD-CL					
	M _{A1}		S	DBSE	L _{F1}	L _{F2}	M _{A1}		S	DBSE	L _{F1}	L _{F2}
	[-]	[Nm]	[mm]	[mm]	[mm]	[mm]	[-]	[Nm]	[mm]	[mm]	[mm]	[mm]
89	M5	8	6.8	80	102	136	M5	8	7	80.4	102.4	136.4
118	M6	14	9.4	79	106	147.5	M6	14	9.8	79.8	106.8	148.3
142	M8	35	9.6	93	125	169	M8	35	9.8	93.4	125.4	169.4
168	M8	35	11.6	112	150	206	M8	35	11.6	112	150	206
200	M10	69	12.0	124	167	235.5	M10	69	12.2	124.4	167.4	235.9
238	M12	120	15.8	144	193	293.5	M12	120	17	146.4	195.4	295.4
295	M14	190	24.0	199	263	391	M14	190	24.2	199.4	263.4	391.4
345	M16	295	25.2	223	301	462	M16	295	25.4	223.4	301.4	462.4





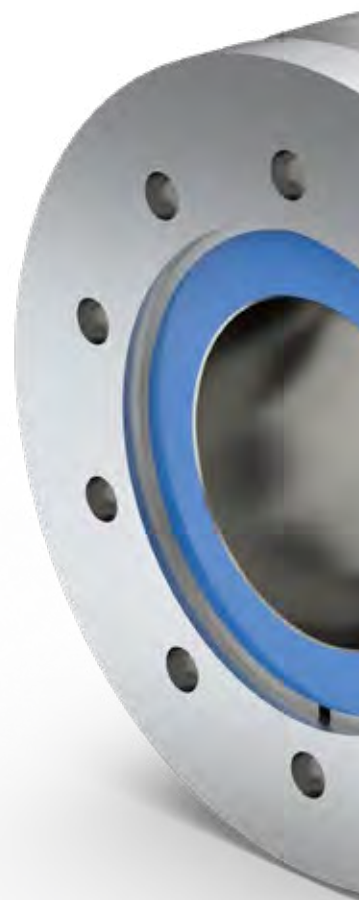

FLEXDUR



SIMPLY **POWERFUL.** 



行业解决方案：

-  发电
-  移动应用
-  测试台架
-  泵 & 压缩机
-  工业
-  船舶与港口技术

总部：

Dipl.-Ing. Herwarth Reich GmbH
Vierhausstrasse 53 • 44807 波鸿
 +49 234 959 16-0
 mail@reich-kupplungen.com
 www.reich-kupplungen.com

请遵守 ISO 16016 保护通告：

未经授权严禁对本文件进行传播及复制或使用和转载文件内容。违者必究。所有专利、实用新型或外观设计注册权利归
本司所有。© REICH - Dipl.- Ing. Herwarth Reich GmbH

2024 年 1 月版

本 FLEXDUR 目录册出版后，之前的 FLEXDUR 文件将有部分失效。所有尺寸均以毫米为单位。本司有权进行尺寸和
结构更改。文字和插图、尺寸和性能数据均经过精心编辑。但仍然不能保证完全的准确性，特别是无法保证产品在技
术、颜色、形式和装备方面均与插图一致，或者产品完全对应插图的比例。同样保留由于印刷错误或疏忽进行更改
的权利。