

Warranty: 24 months

burster

## Battery tester for diagnosis, testing, analysis

MODEL 2560 **NEW**

Preliminary data sheet



### Highlights

- Voltage measurement of 0 ... 5 VDC to 0 ... 60 VDC
- AC resistance range (impedance) 0 ... 1 m $\Omega$  and 0 ... 1  $\Omega$
- Frequency range 0.1 Hz ... 1 kHz
- Temperature measurement 0 ... 60 °C
- Capacitance measurement approx. 25 mAh to approx. 10 Ah
- Very good price / performance ratio
- Extremely compact design
- USB port incl. convenient PC software for configuration, battery test and analysis

### Areas of application

The extremely compact, universal battery tester is a measuring device which is attractively priced and can be operated intuitively via PC software. Irrespective of the battery technology, deployment areas can be found in development, manufacturing, service or maintenance in order to be able to reliably and quickly obtain and evaluate important battery parameters such as open circuit voltage, impedance, temperature and capacitance. Decisive test object characteristics such as charge status, health, heating, operating behavior and damage can be evaluated and determined. Battery tester model 2560 is very suitable for analyzing and testing round or prismatic battery cells which are used in large-scale storage in partially or fully electrified mobility vehicles, industrial trucks, power tools and in communication electronics, for example.

### Product description

The battery tester operates in accordance with the well-tried four conductor measuring method and combines the functionality of a testing device and an analyzer. The measuring device supports exact determination of the real (ohmic component) and imaginary component (capacitive or inductive component) of batteries with the impedance measurement and the spectral (complex) impedance measurement. The measurement results are displayed in a locus curve in accordance with the real component and the imaginary component. The respective battery voltage is also recorded during these measurements.

With the aid of various approximation functions, important model parameters such as serial inductance, series and parallel resistance and double layer capacitance can be determined and evaluated using the intuitively operated PC software. All measurements can be stored or displayed using log viewers and analyzed by means of gap-free history examination.

The capacitance measurement is determined via discharging with a constant current until the end point voltage is reached. You can choose between partial or complete discharging of the battery. A temperature measurement can be carried out on the test object using external Pt1000 measuring sensors. The battery tester is supplied via with 5 VDC via a galvanically isolated USB interface and there does not require an additional power supply.

## Technical data

DC battery voltage measurement								
Range (adjustable)		0 ... 5 VDC			0 ... 60 VDC			
Resolution		0.1 mV			1 mV			
Measuring accuracy		±0.2 % d.A. ± 0.02 % of reading						
Input impedance		50 kΩ						
AC resistance measuring ranges								
Impedance measuring range		1 mΩ	3 mΩ	10 mΩ	30 mΩ	100 mΩ	300 mΩ	1 Ω
AC current		2000 mAss	1000 mAss	200 mAss	100 mAss	20 mAss	10 mAss	5 mAss
DC current		1000 mA	500 mA	100 mA	50 mA	10 mA	5 mA	2.5 mA
Resolution		0.01 %						
Measuring accuracy		±1 % d.A. ± 0.3 % of reading / ±1° Phase						
Frequency range								
Range		0.1 Hz ... 1 kHz						
Time interval for single measurement		< 1 s (8 Hz to 1000 Hz)						
Time interval for entire spectrum		12 s / 84 s						
Amplitude for current application		5 mA to 2 A (discharging, quasi-sinusoidal)						
Temperature measurement (Pt1000)								
Measuring range		0 °C ... +60 °C						
Resolution		0.1 °C						
Measuring accuracy		±1 °C						
Capacitance measurement								
Discharge current		5 mA to 2000 mA (constant current discharge, min. end point voltage 2 V)						
Resolution		approx. 25 mAh to approx. 10 Ah (in accordance with IEC 61960)						
Measuring accuracy		1 % of reading						
Ambient conditions								
Operating temperature		0 °C ... +40 °C						
Storage temperature		-40 °C ... +80 °C						
Humidity		< 80 %, non-condensing						
General data								
Communication interface		USB						
Power supply		Via USB, galvanically isolated						
Power supply / power consumption		5 VDC (via USB connection, galvanically isolated) max. 0.5 W						
Total power dissipation		12 W (depending on measuring current and test object)						
Size		120 x 80 x 42 (L x W x H / mm)						
Weight		Approx. 350 g						
Protection class		III (safety low voltage)						
Protection type		IP 40						
Measuring category		CAT I						
Degree of pollution		II						
EMC interference transmission		EN 61000-6-3 2011-9						
EMC interference immunity		EN 61000-6-2 2006-3 and EN61000-4-3 2011-4						
ESD immunity		EN 61000-4-2 2009-12						
Radio interference		EN55011 2014-11						
Test subject measurement connection		6 pin Lemo PXG, contact protection (four conductor measurement)						
Temperature measurement connection		4 pin Lemo EXG.0B.304.HLN						
Housing		High-quality aluminum						

## Calibration / test interval

We recommend periodic checking at 12 monthly intervals. To do this, please send the device to us.

### Principle of operation

The battery tester operates in accordance with the four-conductor method (Kelvin connection) and has 4 connections for impedance measurement: 2 connections for power input (Force + and Force -) and 2 connections for voltage measurement (Sense + and Sense -). The battery tester applies an AC current  $I_{AC}$  that is relatively small in relation to the load current to the test object (battery, accumulator), and measures the resulting voltage drop  $U_{AC}$  in the mV range.

The AC voltage measurement takes place selectively and synchronously, with results in accordance with the real and imaginary component. Dividing the AC voltage and the AC current results in the complex (AC current) impedance  $Z$ . The real component represents the ohmic component, the imaginary component and the capacitive (or inductive) component, whereby a negative imaginary component means capacitance, and a positive proportion means inductance. The input voltage is measured in parallel to this.

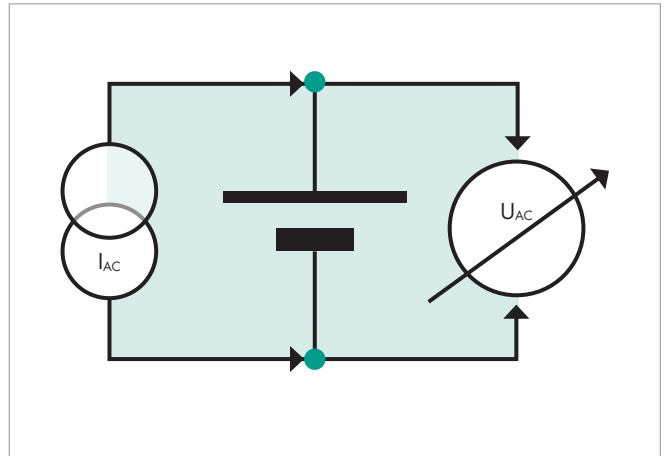

## Operating modes

Battery tester model 2560 and the associated PC software provide a large number of measuring and evaluation functions.

### Single frequency impedance measurement measuring function

In this operating mode, the single impedance of a test object is measured with a previously defined measuring frequency (selectable between 0.1 Hz and 1 kHz) with regard to internal resistance (real component, amount) and reactive component (imaginary component, phase).

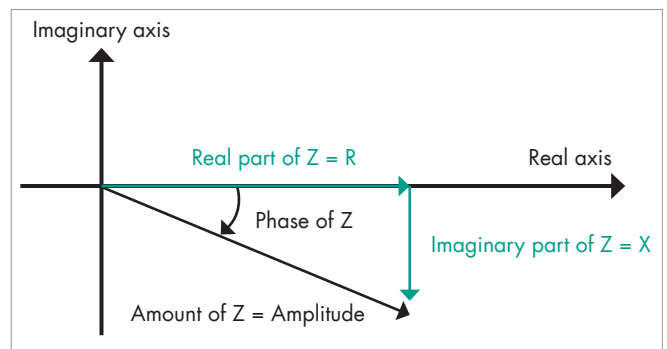

### Spectral measuring function – impedance measurement

In the spectral measurement measuring type, periodic frequency sweeps are set. Starting with the highest frequency (1 kHz), the frequency grids which are available are automatically run through. The results are depicted in a locus curve (real component, imaginary component with the frequency as a measuring parameter). Locus curves which have been determined can be used for comparison or referencing purposes.

Parameters such as the series resistance ( $R_s$ ), the parallel resistance ( $R_p$ ), the series inductance ( $L_s$ ) and the charge status of the test object ( $C_p$ ) can be calculated using an approximation function and information about the battery status can be obtained.

### Capacitance measurement measuring function

The capacitance of the test cell is determined via discharge with constant current until the selectable end point voltage. It is possible to select between full or partial discharge by a previously defined charge value.

If a fully charged battery is connected and discharged until the end point voltage, this corresponds to the measured capacitance of the test object.

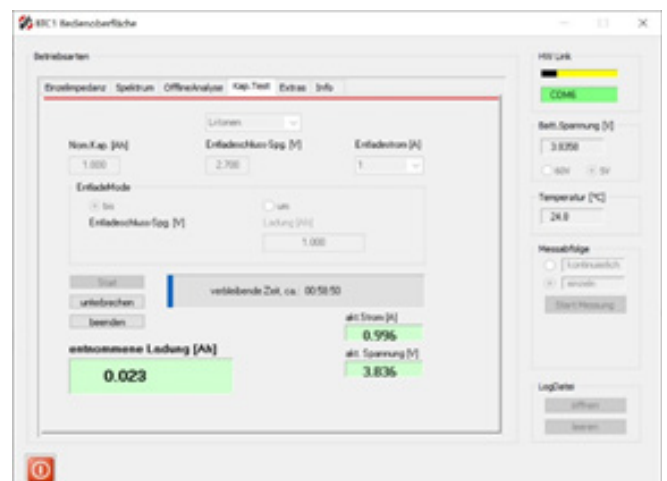

**Temperature measurement**

To determine the temperature of the test object, a Pt1000 sensor can be connected to the Lemo socket attached to the front panel. The temperature can be recorded and logged during the single impedance measurement and also the spectral impedance measurement.

**Voltage measurement**

In parallel to the single frequency or spectral impedance measurement, the terminal voltage (0 ... 5 VDC; 0 ... 60 VDC) is measured.



**Analysis and diagnosis PC software**

The innovative, intuitively operated PC software for battery tester model 2560 is used wherever comprehensive visual analyses, diagnoses, battery condition determination or capacitance and temperature measurements are to be carried out on battery cells or accumulators.

- Convenient device configuration via USB interface
- Management of different operating modes can be defined
- Viewer function
- Backup of settings
- Measurement data logging of the analysis and measurement data, including results
- Handover of test object designations for measurement data logging
- Exporting of measurement data and results into Excel
- Classification function

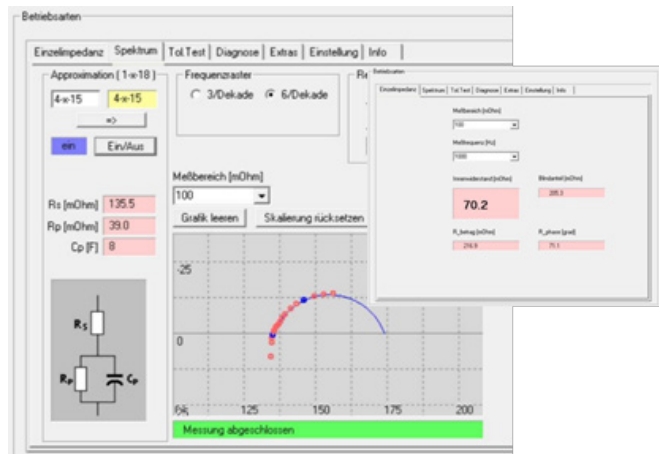

**Accessories**

Order code	
	Measuring cable MK-L 1.0 m cable length, 4 measuring cables with 4 mm laboratory connector for universal connection of standard test terminals or probes
	Measuring cable MK-L SET 1.0 m cable length, 4 measuring cables with 4 mm laboratory connector for universal connection of standard test terminals or probes, including 4 crocodile clips/cable shoe adapters M4/M6/M8 each.
	Measuring cable MK-HV 1.0 m cable length, 2 pairs of twisted measuring cables with 4 mm safety connectors
	Pt1000 temperature sensor, single standard immersion sensor
	USB connecting cable, can 2.0 m cable length be used, included in scope of delivery

**Test object connection**

The customer-provided twisted pairs of measuring cables are connected to the test object via the 4 mm input sockets attached to the front. Separate routing of the pairs of leads to the test object from different sides is recommended. These should be brought together and connected to the test object (battery, accumulator) in pairs.

Measuring socket	Meaning	Battery connection	Measuring cable
red	Force +	Positive terminal	Twist together!
black	Force -	Negative terminal	
Green	Sense +	Positive terminal	Twist together!
blue	Sense -	Negative terminal	

(See operating instructions for further information)

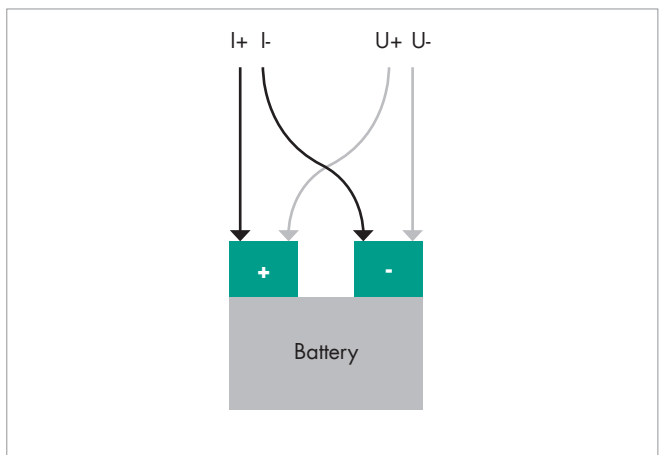

## Order code

Item number	Functions
2560-V20000	U, RAC, RDC, temperature and capacitance measurement